

160 PERIPHERAL EQUIPMENT

Electric Typewriter

This is an IBM electric typewriter modified by Soroban Corporation. It has a standard keyboard. The typewriter is mounted on a cabinet with the controls and power supply inside the cabinet -- connected to the 160 by the input-output cable. It accepts input data at normal typing speeds. It prints output data from the 160 at a rate of 10 to 12 characters per second. Associated with the typewriter is a control panel. It houses two switches and two lights. The switches denote Operation Mode and Input Disconnect.

1609 Card Read and Punch Unit

This is an IBM 521 punching unit. It provides the 160 with punched card input and output. There are three card stations: first reading station, punching station, second reading station. Calculated results are punched at the punching station. At the second reading station, a card can be read for gang punching, re-calculation for proof, and double punch, blank column checking. Cards are fed continuously without interruption for calculation. As the results are being punched in one card, factors are being read from the following card. May be operated as an independent gang punch. It operates at a speed of 100 cards per minute. Two double section, 22-hub control panels and standard complements of self-contacting wires are furnished.

Basic Magnetic Tape Unit

It contains controls for a total of four tape handlers. Uses Ampex FR-300 tape handler, with a character rate of 30 KC. "Change-on-ones" type of recording is used compatible with that used by IBM 727 tape units. Reflective spots indicate beginning and end of tape. Thus, a reel of tape generated by the tape unit can be used on an IBM 727 tape unit and vice versa. Forward, reverse, and rewind tape speed is 150 inches per second. Recording density is 200 characters per inch, with 6 information bits and one parity bit per character. Tape width is 1/2 inch. Data is recorded in variable-length blocks, with practical limits determined by the size of memory. Length of inter-block spacing is approximately one inch. Data transmissions to and from the tape system are in the form of 6-bit words. Tape can be read in either the forward or backward direction. For writing, the control section receives a 6-bit word and generates a parity bit for each word. Reading follows the reverse procedure: 7-bit characters are read off the tape and the lower 6 bits are transmitted to the computer. Parity checks are made on reading and writing by a read-head mounted 0.4 inches following the write head. Parity errors are registered on a flip-flop for subsequent sensing by the computer. A parity error does not immediately halt operations, unless a program stop is specified. The reading and recording heads are electrically isolated on this tape unit. This feature allows the tape to be read back during recording for a positive check on both the recording circuits and the magnetic tape quality. Same unit is available using FR-400 tape handler, with a character rate of 15 KC. Additional magnetic tape units are available.

1606 High Speed Printer

The Line Printer consists of an Anelex series 56-160 printer and the necessary control circuitry. This printer provides high speed printing at a normal rate of 350 lines per minute. It will handle forms from 4 to 20 inches wide and any length up to 22 inches. It provides 120 columns of characters and 47 characters per column. These may be digital, digital and signs, or full alpha-numeric; also foreign language and plotting symbols. It will print on single or multiple carbons, pressure sensitive or heat transfer type papers, pre-printed forms or card stock.

Additional Description - General

Operation of the 160 is sequenced by an internally stored program. This program, as well as the data being processed, is contained in the high-speed, random-access memory. An instruction is a 12-bit word consisting of: a 6-bit function code F, and a 6-bit execution address E. By means of the direct, relative, and indirect addressing features, it is very simple to operate on data in the computer and to make program modifications when desired.

A general purpose input channel and output channel are provided for attaching a variety of input-output devices to the 160 Computer. Standard input-output equipment consists of a Ferranti punched paper tape reader that reads 350 characters per second; and the Teletype high-speed paper tape punch that operates at 60 characters per second. Optional input-output equipment includes an on-line electric typewriter, up to 8 magnetic tape handlers (Ampex FR-300 handlers that operate at 30 KC character rate or Ampex FR-400 handlers that operate at 15 KC character rate), card reader-punch units, and line printer. Input-output transmissions are either a single 6-bit or 7-bit character, or a 12-bit word.

Description of Registers

The 160 Computer contains three operational registers: A, Z, and P. The contents of these registers are shown in arabic numerals (octal notation) on the control panel of the computer. There are also three transient registers: B, F, and S. These registers are described below; a block diagram of the 160 Computer is shown in the figure.

A Register (12 bits): principal arithmetic register. For most arithmetic operations, A operates as a 12-bit subtractive accumulator. The quantity zero is represented by all zeros.

Z Register (12 bits): performs several functions. One, it serves as a buffer register for storage. In this capacity, it receives the word read out of storage and holds the word to be written into storage. Also, for addition and subtraction operations, the contents of the Z register are added to or subtracted from the contents of A.

P Register (12 bits): program control register. Its contents are the address of the current instruction. At the beginning of each instruction, the contents of P are increased by one to provide the address of the instruction; a jump address is entered in P if a jump is called for.

B Register (12 bits): auxiliary arithmetic register. The results of arithmetic operations are first formed in B, then transmitted to the A, Z, or S registers.

S Register (12 bits): functions as the storage address register. Prior to any storage reference, the address word is entered in S. The contents of S are then used to select the storage location involved in the reference.

F Register (6 bits): holds the upper six bits of an instruction word, i.e., the function code, throughout the execution of an instruction. The execution of an instruction is under the control of the quantity in F.

Addressing Modes

In the direct addressing mode, the address refers to a 12-bit operand in one of the first 64 storage locations.

Indirect addressing provides for operand references and jump addresses. Where indirect addressing is used with an instruction, E refers to one of the first 64 storage locations; the contents of this register are then read out and used as the address of the operand or as the jump address.

Relative addressing provides for operand addresses and jump addresses that are in the immediate vicinity of the storage location which contains the current instruction. In relative addressing forward, the E portion is added to the current contents of the program control register P. Thus, the operand or jump address is one of the 63 storage locations immediately preceding the address of the current instruction. An exception is the Indirect Jump, in which the jump address is read from the address found when the contents of P are added to E.

In the no address mode, constants are stored in the address portion of the instruction. The E portion of the instruction is not used as an address. Instead, it is used as a 6-bit operand. This operand is automatically extended to 12 bits, with the upper six bits being zeros. With this feature, arithmetic and logical operations can be carried out with a 6-bit quantity contained in the instruction. Thus the need for entering many constants into memory is eliminated.

CDC 1604

Control Data Corporation Model 1604

MANUFACTURER

Control Data Corporation

APPLICATIONS

Manufacturer

Actual applications include engineering, scientific, business, radar, missile tracking, and educational.

U.S. Naval Postgraduate School

Located at Monterey, California, the system is used for scientific applications, including student and faculty research in practically all phases of the physical sciences; for data processing, including weather prediction, and for simulation, including electronics systems, and games (business, industrial and military).

National Bureau of Standards - Boulder, Colo.

Located at Boulder, Colorado, the system is used for scientific computing on Radio Propagation, Radio Standards, and Cryogenics Research.

Photo by Control Data Corporation

PROGRAMMING AND NUMERICAL SYSTEM

Manufacturer

Internal number system	Binary
Binary digits/word	48
Binary digits/instruction	24
Instructions per word	2
Instructions decoded	62
Arithmetic system	Floating point one's complement Fixed point one's complement
Instruction type	One address
Number range	Fixed point $\pm (2^{47} - 1)$ Floating point 10 bit exponent plus sign, 36 bit coefficient plus sign

Instruction word format

6 bits	3	15
Instruction Code	Index Design.	Execution Address

Indirect addressing built in.

Registers include 6 index registers of 15 bits each and a Ones-complement arithmetic register.

A-Register (Operational) Principal arithmetic register. Functions as a 48-bit accumulator in most arithmetic operations. Quantity zero represented by a binary zero in each stage. Contents of A may be shifted either to the right or left. Shifting may involve only the contents of A or may include the contents of Q. Leftmost sign bit extended on shifts to right; bits shifted off the right end of A or Q are dropped. Left shifts are circular, with lower order bits being replaced by higher order bits. Multiply, divide, and floating point instructions are sequenced operations involving both A and Q.

Q-Register (Operational) Assists accumulator in performing more complicated arithmetic operations. Used with A to perform double precision arithmetic.

Photo by U.S. Navy - Post Graduate School

Q may be shifted right or left, singly or in conjunction with A. Q also contains mask in logical operation.

Program Control Register, U1 Holds program step while the two instructions contained in it are executed. The 48-bit instruction word taken from storage location specified by P and entered in U1, the upper instruction being executed first. Execution of lower instruction follows, except when upper instruction is a jump or when it provides for conditional skipping of lower instruction.

Auxiliary Program Control Register, U2 An accumulator used in the modification of execution address of current instruction. This modification consists of adding contents of an Index Register to execution address of current instruction.

P-Register (Operational) Functions as the program address counter. Provides continuity between individual steps of program by generating the addresses at which individual steps are contained. Upon completion of each sequential step, count in P is advanced by one to specify address of next step. Jump instructions clear P and enter new address in it.

Index Registers, B1-B6 (Operational) Provide modi-

Diagram of Model 1604 Input-Output Facilities

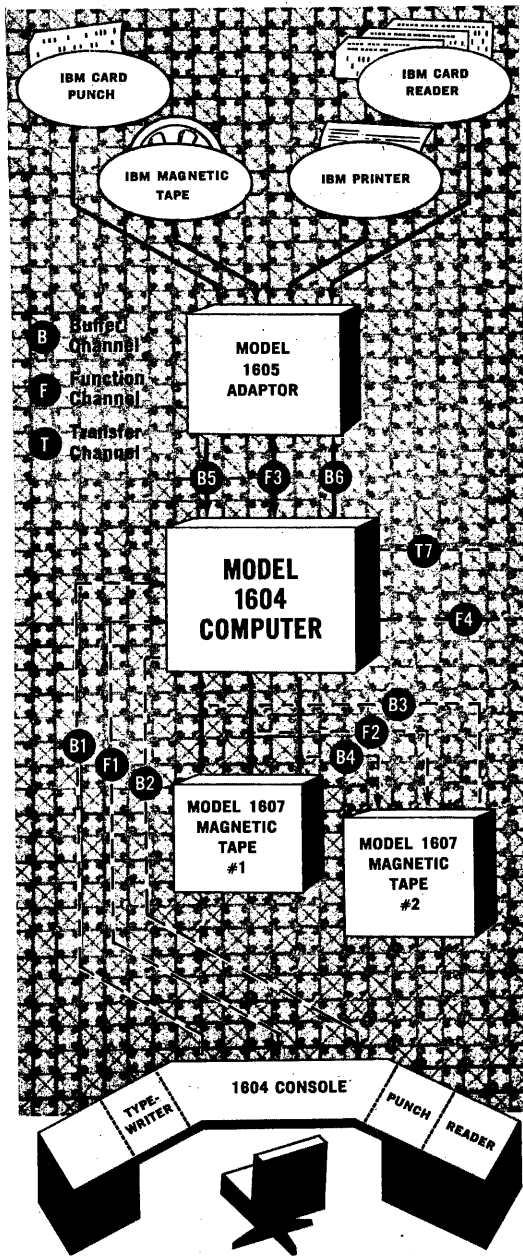

R-Register Functions as exchange register for transmission involving B-Index Registers. Used in advancing or reducing count in a given B-Register. During several instructions, used to count repetitive operations. R used with floating point instructions in performing arithmetic operations on the exponent or characteristic.

X-Register An exchange and auxiliary arithmetic register. All input-output data passes through X.
 External Function Register, 00 Used for exchanging control information with input-output equipment.
 Output Registers, 01 through 04 01 through 03 used for output buffer operations where data is transmitted at speed of input-output equipment. Where high-speed transfer is required, output transfer operations carried out via 04.

ARITHMETIC UNIT

	Incl Stor Access
	Microsec
Add	4.8 - 9.6
Mult	25.2 + .8N
Div	63.6 - 66.4
N = Number of ones in multiplier	
Arithmetic mode	Parallel
Timing	Synchronous
Operation	Concurrent

STORAGE

Manufacturer			
Media	No. of Words	No. of Digits	
Magnetic Core	32,768	48	
Magnetic Tape			
No. of units that can be connected			24 Units
No. of characters/linear inch			200 Chars/inch
Channels or tracks on the tape			7 Tracks/tape
Blank tape separating each record			3/4 Inches
Tape speed			150 Inches/sec
Transfer rate			30K Chars/sec
Stop time			1.2 Millisec
Average time for experienced operator to change reel of tape			20 Seconds
Physical properties of tape			
Width			1/2 Inches
Length of reel			2,500 Feet
24 tape stations is a practical maximum, although more may be used.			
U.S. Naval Postgraduate School			
Medium	No. of Words	No. of Dig/Word	Access Microsec
Magnetic Core	32,768	48	approx. 4.8
National Bureau of Standards - Boulder, Colo.			
Magnetic Core	32,768	48	4.8 (effective)

fication of execution addresses in program loops. Contents of an Index Register can be advanced each pass through a loop, with an exit initiated on a given threshold. Alternate approach allows an Index Register to be preset, then reduced by one count each pass through the program-with an exit after zero.

Storage Address Registers, S1-S2 Represent even and odd 16,384-word memory units respectively. Receive addresses of instructions from P and addresses of operands from U2.

Storage Restoration Registers, Z1-Z2 Represent even and odd 16,384-word memory units respectively. Hold the 48-bit word to be written in a given storage location.

INPUT

Manufacturer		
Media		Speed
Paper Tape		350 char/sec
Typewriter		
Punched Cards		150 cards/min
Magnetic Tape		30,000 char/sec
Faster punched card units will be available soon.		
U.S. Naval Postgraduate School		
Paper and Magnetic Tapes		

National Bureau of Standards - Boulder, Colo.

Media	Speed
IBM 088 Collator	650 cards/min
Two read feeds are available.	
Paper Tape (Ferranti)	350 char/sec

OUTPUT

Manufacturer	Speed
Media	
Paper Tape	60 char/sec
Typewriter	
Punched Cards	100 cards/min
Magnetic Tape	30,000 char/sec
Line Printer	667/1,000 lines/min
U.S. Naval Postgraduate School	
Paper Tape	60 char/sec
Magnetic Tape	150 in/sec 200 char/in
Monitoring Typewriter	
IBM 717 Printer	150 lines/min 120 char/line
Off line Mag tape to printer	
National Bureau of Standards - Boulder, Colo.	
IBM 523 Punch	100 cards/min
IBM 407 Printer	150 lines/min
Magnetic Tape	

CIRCUIT ELEMENTS OF ENTIRE SYSTEM

Manufacturer	Quantity
Type	
Diodes	100,000
Transistors	25,000
Magnetic Cores	1,500,000

POWER, SPACE, WEIGHT, AND SITE PREPARATION

Manufacturer	
Power, computer	7.5 Kw
Volume, 1604 Computer	98 cu ft
Volume, 1604 Console	112 cu ft
Area, computer	17 sq ft
Area, console	30 sq ft
Floor loading	150 lbs/sq ft
	2,650 lbs/concen max
Capacity, air conditioner	5 Tons
Weight, computer and console	3,450 lbs
Weight, air conditioner	500 lbs

Power, space and weight figures are for 1604. Computer and console peripheral equipment is not included. The alternator is driven by a 15 HP motor.

U.S. Naval Postgraduate School

Power, computer	4 Kw
Room size	2,800 sq ft
Floor loading	200 lbs/sq ft
	700 lbs concen max
Capacity, air conditioner	25 Tons
Weight, computer	2,200 lbs

The lobby section of one of the school buildings was partitioned. False flooring, air conditioning and power were installed in the laboratory section which houses two computers (CDC-1604 & NCR-102A) and their associated peripheral equipment.

National Bureau of Standards - Boulder, Colo.

Power, computer	15 Kw
Room size	24 ft x 24 ft
Capacity, air conditioner	6 Tons

System is installed on a raised floor in a specially prepared computer room.

PRODUCTION RECORD

Manufacturer	
Number produced to date	6
Number in current operation	6
Number in current production	10
Number on order	6
Anticipated production rates	1 per month
Time required for delivery	9 months

COST, PRICE AND RENTAL RATES

Manufacturer	Purchase Price	Lease Price/1 Year	Lease Price/3 Year
Basic computer, with 8,192 words Mag Core Stor	\$750,000	\$22,500	\$18,750
16,384 words Mag Core Stor	830,000	25,000	20,750
32,768 words Mag Core Stor	990,000	30,100	24,750

Above computer includes:
 Magnetic Core Storage:
 Two phase system with
 3.2 microseconds effective cycle time, alternate banks
 6.4 microseconds cycle time, each bank

Fixed Point Arithmetic
 Floating Point Arithmetic Feature
 Indirect addressing
 Control and Maintenance Console
 Motor-generator

Input Punched Paper Tape Reader (7 channels, 350 characters per second)

Output Punched Paper Tape Punch (7 channels, 60 characters per second)

Input/Output Modified IBM Typewriter (direct-connected)

Installation and checkout at customer premises
 Site preparation not included

Maintenance and instruction books

Model 1607 Magnetic Tape Subsystem	\$145,000	\$5,050	\$3,625
------------------------------------	-----------	---------	---------

Includes Magnetic Tape Synchronizer
 Four magnetic tape handlers
 30 KC character rate
 6 information bits, 1 parity bit per character
 Parity-bit check on read and write
 48-bit assembly for central computer
 IBM 727 Format

Note: Up to 6 Magnetic Tape Subsystems can be used with each Model 1604.

Model 1605 Adaptor	\$70,000	\$2,050	\$1,750
--------------------	----------	---------	---------

Permits direct communication between Model 1604 and following IBM input/output equipment:

IBM 714 card reader (via 759 control unit)
 IBM 727 magnetic tape units (via 754 synchronizer)
 IBM 722 card punch (via 758 control unit)
 IBM 717 line printer (via 757 control unit)

Transistor Chassis Tester \$9,000 (non-automatic)

Purchase Price	Lease Price/Month	
	1 Year Contract	3 Year Contract

Modifications Added after Model 1604 Construction or Delivery:

Magnetic Core Storage:
 Add 8,192 words to 1604 with 8,192 words \$100,000
 Add 16,384 words to 1604 with 16,384 words 200,000
 Add Model 1607 Magnetic Tape Subsystem (each) 150,000

Model 1606 High Speed Printer 110,000 3,300 3,300
 Operates at a rate of 1,000 lines per minute with the 1604.

All prices are f.o.b. Minneapolis, Minnesota, and do not include Federal, State, and Local Taxes which may be applicable. Prices are subject to change without notice.

U.S. Naval Postgraduate School
 Computer, with 4 tape drives, console, photo electric reader and teletype punch is approx. \$800,000.
 IBM 717, 727 and 757 rent at approx. \$2300 per month.
 Maintenance/service contract with Control Data Corporation amounts to \$17,500/year.
 National Bureau of Standards - Boulder, Colo.
 Rates for basic system is \$36,660 per month.
 Rental rate for IBM Input-Output equipment is \$1,340/month.

PERSONNEL REQUIREMENTS

Manufacturer

	One 8-Hour Two 8-Hour Three 8-Hour		
	Shift	Shifts	Shifts
Engineers	1	2	2
Technicians	1	1	2

Training made available by the manufacturer to the user includes regularly scheduled training courses, furnished for customer personnel at our plant in Minneapolis, Minnesota. These courses are included in the equipment price.

U.S. Naval Postgraduate School

	One 8-Hour Shift	
	Used	Recommended
Supervisors	1	
Programmers	1	3
Clerks	1	3
Operators		2
Engineers	1	2
Technicians	1	2

Operation tends toward open shop.

Methods of training includes course work given in the Engineer School on programming, operation and applications and also seminars are given at the school.

The computers are available for student and faculty research 24 hours per day. Those students and faculty who have been checked-out on the operation of the computers and peripheral equipment are permitted out-of-hours production runs on the computers. Potentially the school has approximately 1000 programmer-operators under this system. At the present time the

CDC 1604 operates approximately 14 hours per day and the NCR 102A 20 hours per day, 7 days per week.
 National Bureau of Standards - Boulder, Colo.

	One 8-Hour Shift
Supervisors	1
Analysts	3
Programmers	3
Operators	2

Methods of training used include programming training courses using CDC manuals.

RELIABILITY, OPERATING EXPERIENCE, AND TIME AVAILABILITY

Manufacturer

System features and construction techniques utilized by manufacturer to insure required reliability include solid state components throughout and wide tolerances designed into all circuits.

U.S. Naval Postgraduate School
 Passed Customer Acceptance Test 16 Jan 60
 Time is not available for rent to outside organizations.

ADDITIONAL FEATURES AND REMARKS

Manufacturer

Outstanding features include 48 bit word length, 6 buffer input-output channels, program interrupt feature, six index registers, and floating point arithmetic.

Unique system advantages include high speed transfer channel, and satellite operation with 160 computer.

Summary of Buffer Operation

The Model 1604 buffer control continually interrogates all communication channels to determine if a peripheral equipment is ready to send or receive information.

If a peripheral equipment has data ready for transfer, interrogation waits momentarily while a word is being buffered. The buffer control then resumes interrogating the communication channels.

Buffering initiates communication between computer memory, the three buffer input channels, and the three buffer output channels. These buffer information in and out asynchronously with the main computer program.

The three buffer input channels and the three buffered output channels, the interrupt line, and the real-time clock are rapidly scanned by a scanner which looks for action requests from all channels. These action requests are initiated by the peripheral equipment by indicator "flags". A complete scan is made in 3.2 microseconds, which corresponds to the phase rate of magnetic core memory.

When a request is detected by the scanner, the main computer program is halted momentarily to move the data between memory and the requesting channel. The main program proceeds immediately after this action unless the scanner detects that another channel has requested servicing. For example, if the system includes six 1607 magnetic tape systems, all three buffered input channels and all three buffered output channels of the 1604 can operate in the buffer mode, simultaneously servicing at full tape-rate three 1607 magnetic tape units operating in the read mode and three 1607 magnetic tape units operating in the write mode.

Summary of High Speed Transfer Operation

The main computer program performs the high-speed input-output transfer of information between 1604's or between one 1604 and peripheral equipment having comparable speed.

Only one instruction is required for a block of input or output data. A 48-bit word is transferred in or out in 4.8 microseconds.

All transfer operations are carried out via channel 7.

Summary of Program Interrupt

The Model 1604 recognizes an interrupt signal which may be either a signal indicating that a peripheral equipment has completed sending or receiving information or it may be a fault condition, e.g., an overflow.

A subroutine determines what has caused the interrupt, e.g., what specific peripheral equipment is causing the interrupt and on which channel the interrupt is taking place.

The subroutine takes action with the originating peripheral equipment by first removing the interrupt signal to prevent re-recognition.

The appropriate condition is set up in compliance with the interrupt. If it has come from a peripheral equipment, the action is completed-after which there is a return to the main computer program.

Summary of External Function

This instruction provides control and communication between the Model 1604 and peripheral equipment. It contains eight sub-instructions which select and sense peripheral equipments, or activate buffer channels.

The select sub-instruction (74.0) is interpreted as follows: the leftmost 6 bits are the operation code, the next 3 bits designate that this is a select sub-instruction, the next 3 bits are the channel or internal condition selection code, the next 3 bits are the equipment selection code, and the last 9 bits specify the operation for the selected equipment.

The channel activate sub-instructions 74.1 through 74.6 are interpreted as follows: the leftmost 6 bits are the operation code, the next 3 bits designate that this is an activate sub-instruction (plus indicating the channel), and the last 15 bits indicate the initial address for data storage in the buffer operation.

The sense sub-instruction 74.7 is interpreted as follows: the leftmost 6 bits are the operation code, the next 3 bits designate that this is a sense sub-instruction, the next 3 bits are the channel or internal condition selection code, the next 3 bits are the equipment selection code, and the last 9 bits specify the operation for the selected equipment.

Model 1607 Magnetic Tape System

A Model 1607 Magnetic Tape System consists of four Ampex magnetic tape handlers. The system is self-contained in a single cabinet, including data-handling and control circuitry; 48-bit assembly and disassembly registers; parity bit assignment for each written character; parity bit read-check immediately following each character written; longitudinal parity bit generation and recording at end of block; parity bit detection for each character read; and end of tape sensing.

Each 1607 tape system can be connected to any of the three buffer input and three output channels, and each 1607 is independently addressable. A number of 1607's can be connected to a 1604 Computer.

Simultaneously among these 1607 tape systems, three tape handlers can be reading, and three tape handlers can be writing. Each 1607 system has the facility for simultaneously reading from one tape handler and writing on one tape handler, while the remaining two tape handlers are rewinding. Any tape can read either in a forward or reverse direction.

Magnetic tapes of the 1607 tape system are completely compatible electrically and mechanically with IBM Model 727 magnetic tape handlers.

Model 1605 Adaptor

The Control Data Model 1605 Adaptor permits communication between the 1604 Computer and any of the following IBM peripheral equipment:

- 714 Card Reader (via 759 Control Unit)
- 727 Magnetic Tape Units (via 754 Synchronizer)
- 717 Line Printer (via 757 Control Unit)
- 722 Card Punch (via 758 Control Unit)

The 1605 selects one of these peripheral equipments, as well as the operation to be performed, on the basis of an instruction from the main computer program. For example, a buffer instruction initiates the transfer of information between the 1604 Computer and the selected equipment via the Model 1605 Adaptor. A parity check is made on all information transmitted from the 1605 to peripheral equipment.

Each 1605 Adaptor can be connected to any of the three buffer input and three buffer output channels, and each 1605 is independently addressable. The 1605 has the same 48-bit input and output buffer register characteristics as the 1607 Magnetic Tape System. A number of 1605's together with a number of 1607's can be operated with a single 1604 Computer.

For special applications, Control Data Corporation will supply special input-output adaptors for peripheral equipments, such as special display and output systems, radar and sonar systems, digital communication systems, and real-time instrumentation systems.

FUTURE PLANS

U.S. Naval Postgraduate School

Plans include procurement of the CDC 160 system consisting of the Central Processor, Card Reader and Punch, Magnetic Tape and Printer. This system can be connected on-line to the CDC 1604 and used either on or off line.

INSTALLATIONS

- U. S. Naval Postgraduate School, Monterey, Calif.
- National Bureau of Standards, Boulder, Colo.
- U. S. Army Signal Corps, Signal Procurement Office, Fort George G. Meade, Maryland
- U. S. Navy, Bureau of Ships, Washington 25, D. C.
- U. S. Naval Air Materiel Center, Aeronautical Structures Laboratory, Philadelphia 12, Pennsylvania
- U. S. Air Force Ballistic Missile Center, Air Materiel Command, Los Angeles 45, California
- U. S. Air Force 4925 T.G.A. (Area E), Kirtland Air Force Base, Albuquerque, New Mexico (Proposed)
- U. S. Air Force, Vandenberg Air Force Base
- U. S. Air Force Structures Test Laboratory, WADC, Wright Field, Dayton, Ohio
- Convair Astronautics, Dayton, Ohio
- Lockheed Aircraft Corporation, Missiles Systems Division, Sunnyvale, California (2)
- Institute for Defense Analyses, Weapons Systems Evaluation Division, Room 1D863, Pentagon, Wash 25, D.C.
- Institute for Defense Analyses, Upper Payne Bldg., 76 1/2 Nassau Street, Princeton, N. J.
- New York University, University Heights, NYC 53, NY
- University of California, Institute of Geophysics, La Jolla, Calif.

CDC 1604

CIRCLE

Circle Digital Computer

MANUFACTURER

Hogan Laboratories, Incorporated

APPLICATIONS

Manufacturer
General purpose, scientific computation
Engineer Research and Development Laboratories
Scientific and engineering computation

PROGRAMMING AND NUMERICAL SYSTEM

Internal number system	Binary
Binary digits per word	40 - 44 plus 2 sign digits
Binary digits per instruction	20
Instructions not decoded	3
Instructions per word	2
Instructions decoded	64
Instructions used	33

Photo by Hogan Laboratories, Incorporated

Arithmetic system	Fixed point
Instruction type	One address code
Number range	-1 to +1 ($1-2^{-44}$)

Shift, Print, Convert Binary to Decimal, and Feed
Instructions make use of Address Digits to determine
number of shifts, digits, etc.

ARITHMETIC UNIT

	Exclud Stor Access
	Microsec
Add	500
Mult	20,000
Div	20,000
Construction	Vacuum tubes

Rapid access word registers Operating Registers
 Basic pulse repetition rate 82 Kc/sec
 Arithmetic mode Serial
 Timing Synchronous
 Operation Sequential

Conversion from decimal to binary requires 2,000
 microseconds and one instruction.

STORAGE

Medium	Words	Microsec Access
Drum	1,024-4,096	8,000 (avg)
	42-46 digits per word	

INPUT

Media	Speed
Paper Tape (Flexowriter)	10 dig/sec
Keyboard (Flexowriter)	Manual
Paper Tape (Reader)	30 dig/sec

The paper tape reader is optional.

OUTPUT

Media	Speed
Hard Copy (Flexowriter)	10 dig/sec
Paper Tape (Flexowriter)	10 dig/sec

CIRCUIT ELEMENTS OF ENTIRE SYSTEM

Tubes	800-1,000
Tube types	3
Different plug in units	18
Separate cabinets	2

CHECKING FEATURES

Even-odd check on instructions
 Programmed check is normally used.

POWER, SPACE, WEIGHT, AND SITE PREPARATION

Power, computer	3 - 3.5 Kw
Volume, computer	54-81 cu ft
Weight, computer	1,600 lbs

PRODUCTION RECORD

Number produced	2
Number in current operation	2

This system is no longer being manufactured.

COST, PRICE AND RENTAL RATES

Approximate cost of basic system
 \$80,000 with 4,096 word storage
 \$60,000 with 1,024 word storage
 Optional features at extra cost were:
 Twenty binary digit word operation
 Special orders for unusual problems checking
 2,048 word storage

PERSONNEL REQUIREMENTS

Daily Operation	One 8-Hour Shift	Two 8-Hour Shifts	Three 8-Hour Shifts
Engineers	0.5	0.5	0.5
Technicians	1	2	3

RELIABILITY, OPERATING EXPERIENCE, AND TIME AVAILABILITY

Manufacturer	
Good time	813 Hours
Attempted to run time	996 Hours
Operating ratio (Good/Attempted to run time)	0.82
Passed Acceptance Test	June 54

INSTALLATIONS

U.S. Army Corps of Engineers
 Engineer Research and Development Laboratories
 Fort Belvoir, Virginia
 Westinghouse Electric Company
 Atomic Products Division
 Pittsburgh, Pennsylvania

CUBIC AIR TRAFFIC

Cubic Air Traffic

MANUFACTURER

Cubic Corporation

APPLICATIONS

Computer is intended for future air traffic control applications. The computer now is a special-purpose unit, providing 42-target capacity when used with Cubic Corporation c-w tracking equipment. The computer is a special-purpose, magnetic memory-drum variety (used with MOPIAR Cubic multi-aircraft tracking system) which sequentially determines slant range and two direction cosines by phase-measurement techniques to each of 42 separate airborne targets at the rate of 4 samples (each) per second. Input equipment converts phase information into a series of binary numbers. The computer successively performs, for each input sample, (a) special digital smoothing and filtering operations on each input binary number, (b) ambiguity resolution between overlapping number digits to produce a single range and two direction cosine numbers, (c) computation of aircraft X, Y, and Z position data and (d) conversion and transmission of computed X, Y, and Z positions in IBM 704 format over transmission lines.

PROGRAMMING AND NUMERICAL SYSTEM

Internal number system	Binary
Binary digits/word	20
Arithmetic system	Fixed point
Instruction type	Words handled serially

Arithmetic unit effectively programmed to operate on recirculating data corresponding to particular target sample being handled.

ARITHMETIC UNIT

	Incl. Stor. Access Microsec	Exclud. Stor. Access Microsec
Add	250	250
Mult	250	250
Construction (Arithmetic unit only)		
Transistors	750	
Arithmetic mode	Serial	
Timing	Synchronous	
Operation	Sequential	

Combination external high-speed multiplier and square-root extractor employed for multiplication and square rooting. Additions performed during drum recirculation.

STORAGE

Medium
Magnetic Memory Drum
Digital filtering requires equivalent of 168 words; ambiguity resolution and coordinate conversion are both performed in temporary storage corresponding to 5 words in length. Drum has 12 recirculating channels of approximately 20,500 bits total.

INPUT

Medium

Input equipment includes special phase-to-digital conversion equipment consisting mainly of flip-flop counters and clocks. Its overall operation is programmed by the memory drum.

OUTPUT

Medium

A Cubic standard unit (Model DH-10) places the computed X, Y, and Z target sample values in IBM 704 format on output transmission lines.

CIRCUIT ELEMENTS OF ENTIRE SYSTEM

Type	Quantity
Diodes	2,000
Transistors	2,600

Computer itself has 750 transistors, input equipment has 1200 transistors, and the DH-10 output unit has 600 transistors.

CHECKING FEATURES

Data sample is not taken if a poor signal is received from the target. Also, the basic digital filtering technique is self-correcting in the event of intermittent arithmetic failures.

PRODUCTION RECORD

Number on order	1
Time required for delivery	12 months

This computer is intended for future air-traffic control application.

ADDITIONAL FEATURES AND REMARKS

Special-purpose techniques enable this relatively slow, serial memory-drum computer, with external high-speed multiplier, to perform slightly more arithmetic operations per unit time than can be performed by the IBM 709 class of general-purpose computers.

CUBIC TRACKER

Cubic Tracker

MANUFACTURER

Cubic Corporation

APPLICATIONS

All digital computers built by Cubic are Special Purpose Fixed Program Real Time Computers. Two are in operation at PMR. Five are scheduled for delivery to WSMR in September, 1960. One in production for NOTS. Prototype developed and delivered to Eglin A.F.B. Systems are used on line in real-time.

PROGRAMMING AND NUMERICAL SYSTEM

Internal number system Binary
Binary Digits/word up to 21
Arithmetic system Fixed point
There are several modes of operation, each one containing its own program. Arithmetic Section contains 21-bit shift registers plus numerous index registers.

ARITHMETIC UNIT

Incl. Stor. Access Exclud. Stor. Access
Microsec Microsec
Add 20 10
Construction (Arithmetic unit only)
Transistors 100 - 2N597, 100 - TL778
Arithmetic mode Serial
Timing Synchronous
Operation Sequential

STORAGE

Media	No. of Words	No. of Digits/word	Access Microsec
Flip-Flops	64	8 - 20	10/bit
Magnetic Tape			
No. of units that can be connected			1 Unit
No. of characters/linear inch			200 Chars/inch
Channels or tracks on the tape			7 Tracks/tape
Blank tape separating each record		.367 - .7045	Inches
Tape speed		30 - 1.875	Inches/sec
Transfer rate		15 k/s	Chars/sec
Width			0.5 Inches

INPUT

Medium Speed
Flip Flop 96 Kc

OUTPUT

Medium Speed
Flip Flop 96 Kc

CIRCUIT ELEMENTS OF ENTIRE SYSTEM

Type	Quantity	Use
Diodes		
PSI720	200	Gating
1N276	450	Gating
1N270	600	Gating
Transistors		
2N597	600	Low speed Flip Flop
2N501	600	High speed Flip Flop
TL778	200	Nor Gates
2N385	200	Emitter Follower

CHECKING FEATURES

In the test mode of operation all inputs can be simulated and the clock switched to manual.

POWER, SPACE, WEIGHT, AND SITE PREPARATION

Power, computer	1 Kw
Power, air conditioner	1 Kw
Volume, computer	200 cu ft
Volume, air conditioner	50 cu ft
Area, Computer	40 sq ft
Area, air conditioner	20 sq ft
Room size, computer	20 x 20
Floor loading	50 lbs/sq ft
Capacity, air conditioner	1 Ton
Weight, computer	2,000 lbs
Weight, air conditioner	1,000 lbs

PRODUCTION RECORD

Number produced to date	7
Number in current operation	2
Number in current production	5
Number on order	5
Anticipated production rates	12/year
Time required for delivery	8 - 12 months

COST, PRICE AND RENTAL RATES

List of Components of Basic System
Digital phasemeter
Processor
Format translator
Tape handler
List of Additional Equipment
Co-ordinate Converter
Test unit
Field services are available.

PERSONNEL REQUIREMENTS

System requires one operator for each 8-hour shift. Training made available by the manufacturer to users includes in plant and field training.

RELIABILITY, OPERATING EXPERIENCE, AND TIME AVAILABILITY

All transistors undergo an aging process.

ADDITIONAL FEATURES AND REMARKS

Outstanding features include reliability and simplicity.

FUTURE PLANS

Computers now in production contain automatic calibration.

CYCLONE

CYCLONE

MANUFACTURER

Iowa State University

APPLICATIONS

Utilized for general purpose computing to support research work on campus.

PROGRAMMING AND NUMERICAL SYSTEM

Internal number system	Binary
Number of binary digits/word	40
Number of binary digits/instruction	20
Number of instructions/word	2
Total number of instructions decoded	112
To be increased to 152 when modifications are completed	
Arithmetic system	Fixed point (Fractional base)
Instruction type	One address
Number range	$-(1 - 2^{-39}) \leq n \leq (1 - 2^{-39})$

Photo by Iowa State University

Instruction word format

4 bit basic op	4 bit variant	12 bit address	4 bit basic op	4 bit variant	12 bit address
----------------------	------------------	-------------------	----------------------	------------------	-------------------

Automatic built-in subroutines include multiplication.

Automatic coding assembly program will be completed with machine modification.

Registers include an accumulator register, a multiplier-quotient register, an operand register, and an order register.

ARITHMETIC UNIT

	Incl. Stor. Access	Exclud. Stor. Access
	Microsec.	Microsec.
Add	100 av.	70
Mult	990 av.	960
Div	1200 av.	1170

Construction, arithmetic unit only

Type	Quantity
Vacuum tubes	
5844	1,521
7044	386
5670	431
5726	233

Arithmetic mode	Parallel
Timing	Asynchronous
Operation	Sequential

STORAGE

Medium	No. of Words	No. of Digits	Access Microsec
Williams tube Electro-static	1,024	40,960	30 av.

INPUT

Medium	Speed
Paper Tape - 5 level	300 char/sec
Local Design and construction	

OUTPUT

Media	Speed
Paper Tape -5 level	60 char/sec
Model 28 Teleprinter	10 char/sec

CIRCUIT ELEMENTS OF ENTIRE SYSTEM

Type	Quantity
Tubes	
7044	386
6571	40
813	4
6x4	8
5844	1,521
6080	12
6005	61
5726	233
5654	113
C6J/K	18

CHECKING FEATURES

Fixed	
Division error	
Optional	
CRO on memory read amplifier	
Single order execution	
Step-wise gating within single order execution	

POWER, SPACE, WEIGHT, AND SITE PREPARATION

Power, computer	19 Kw
Volume, computer	400 cu ft
Area, computer	62 sq ft
Room size, computer	18 ft x 25 ft
Floor loading	150 lbs/sq ft
Weight, computer	5,000 lbs
Capacity, air conditioner	6 Tons

PRODUCTION RECORD

Number produced to date	1
Number in current operation	1
Not manufactured for sale.	

PERSONNEL REQUIREMENTS

	One 8-Hour Shift	Two 8-Hour Shifts	Three 8-Hour Shifts
Analysts			
Programmers	8	12	16
Coders			
Operators	1	2	3
Engineers	1	2	2
Technicians	1	2	2

Training made available to users includes programming classes conducted on a regular schedule.

Operation tends toward open shop.

RELIABILITY, OPERATING EXPERIENCE, AND TIME AVAILABILITY

Good time	40.9 hrs/week av.
Attempted to run time	41.2 hrs/week av.
Operating ratio (good time/attempted to run time)	0.992

Above figures based on period 1 May to 30 Jun 60. System was placed in operation in Jul 59.

Premium components, all connections soldered. Greatest source of failure is input-output equipment. Anticipated error rate is one error in 40 hours of operation.

ADDITIONAL FEATURES AND REMARKS

The prototype of this machine is ILLIAC, the University of Illinois Digital Computer. Pertinent information on this system will be found under this listing.

FUTURE PLANS

Plans for new components include a 64 word output buffer memory (mag. core) (under construction), a 16,380 word mag. core memory (under construction to replace 1,024 word Electrostatic Williams tube (CRT) memory, and two IBM 726 tape units to be coupled into computer (tape units on hand).

Under consideration are a card reader, a CRT output camera, and a high speed line printer.

INSTALLATIONS

Iowa State University
Ames, Iowa

DATA MATIC 1000

Datamatic 1000 Electronic Data Processing System

MANUFACTURER

Minneapolis Honeywell Regulator Company
DATAmatic Division
Newton 61, Massachusetts

APPLICATIONS

Manufacturer

System is designed and used for commercial (business) and scientific applications.

Baltimore & Ohio Railroad Company

Located on the 10th Floor, B&O Central Building, Baltimore, Maryland, the system is used for payroll, freight revenue accounting, and car accounting.

First National Bank of Boston

Located at the Main Office in Boston, Massachusetts, the system is used for Deposit Accounting, Check Reconciliation, and Corporate Trust Accounting including maintenance of stockholders' ledgers, preparation and processing of cash dividends, stock dividends, proxies, addressing mailable materials, stock subscriptions, etc. It is used for Loan Accounting, including factoring (accounts receivable) consumer loans, commercial and real estate loans, revolving Check-Credit loans, etc. Additional applications for the future include Savings Accounting, Payroll, Expense Distribution, Personal Trust Account-

Photo by Minneapolis-Honeywell Regulator Company

ing and Safe Deposit Accounting.

Michigan Hospital Service

Located on the 6th Floor at 441 E. Jefferson, Detroit 26, Michigan, the system is used for daily maintenance of subscriber records and verification of hospital and medical benefits, premium billing, premium accounting and statistics, and claim accounting and statistics.

Minneapolis-Honeywell Regulator Co.-TCG Division
Located at 2753 4th Avenue South, Minneapolis, Minnesota, the system is used for payroll, account distribution, accounting ledgers, factory labor efficiency, file maintenance, sales statistics, factory scheduling, standard cost calculation, and inventory extension.

Treasury Department

The system is located on the Second Floor at 214 Seventh Street, Parkersburg, West Virginia. Operations are concerned with the issuance and retirement of Series E, United States Savings Bonds in punch card form sold to the public beginning October 1, 1957.

Photo by the First National Bank of Boston

The original bonds and registration stubs are used to prove the accuracy of shipments from issuing and paying agents and establish alphabetic and numeric registration records to provide a status record of every United States Savings card bond printed. Alphabetic files are maintained by the name of the bond owner and numeric files are maintained by bond serial number to reflect the issuance and retirement of each bond. These records serve as search media to answer inquiries relative to card bond holdings and the status thereof. Reports are produced to reflect classified charges to the U.S. Treasurer's account and to provide the Division of Public Debt Accounts and Audit, Washington, with accounting data for the maintenance of outstanding savings bond interest accounts.

PROGRAMMING AND NUMERICAL SYSTEM

Manufacturer	
Internal number system	Binary coded decimal and coded alphanumeric
Decimal digits/word	12
Alphanumeric digits/word	8
Decimal digits/instruction	12

Instructions per word	1
Instructions decoded	1
Arithmetic system	Fixed point
Instruction type	Three address (normal) Four address (subsequence operation)
Number range	0-9, 0-16 and 0-64
Floating point operation	may be programmed.

ARITHMETIC UNIT

Manufacturer		
	Incl Stor Access	Exclud Stor Access
	Microsec	Microsec
Add	230.4	58
Mult	1,008	835
Div	2,304	2,131
Construction	Vacuum tube amplifiers, crystal diodes logic and packaged type construction.	
Rapid access word registers		7
Arithmetic mode		Serial
Timing		Synchronous
Operation		Sequential

Photo by Baltimore and Ohio Railroad

System is primarily sequential. Transfer of information to and from the high speed storage unit is concurrent. The operation times given above under "Including Storage Access" include checking time. The capacity of the accumulator is 11 decimal digits with sign in addition and subtraction or 22 decimal digits with sign in multiplication and division. Parallel reading and writing of 31 channels on magnetic tape with serial handling of bits comprising each character and word. Access to high speed storage is parallel. Arithmetic operations are serial. Decimal digits are in binary coded decimal, alphanumeric characters are in a six-bit code.

STORAGE

Manufacturer	No. of Words	Decimal Digits	Access Microsec
Media			
Magnetic Cores	2,000	24,000	12
Magnetic Cores	248	2,976	20
Magnetic Tape			
No. of units that can be connected			100 Units
No. of chars/linear inch	600 dec,	400 alpha	char/in
Channels or tracks on the tape			31 Channels
Tape speed			100 Inches/sec
Transfer rate	60,000 dec,	40,000 alpha	char/sec

Physical properties of tape

Width	3 Inches		
Length of reel	2,700 Feet		
Composition	Plastic sandwich		
Baltimore & Ohio Railroad Company			
Medium	No. of Words	No. of Digits/Word	
Core	2,000	12 num 8 alpha	
First National Bank of Boston			
Medium	No. of Words	No. of Digits	Access
Core	2,000	24,000	Microsec 28
Michigan Hospital Service			
Magnetic Core	2,000	24,000	28.8/52-bit word
Minneapolis-Honeywell Regulator Co.-TCG Division			
Core	2,000	12	10
Treasury Department			
Ferrite Core	2,000	24,000	Approx. 10
Magnetic Tape	3,100,000	37,200,000	2.5 Min.

The ferrite core storage is internal, the magnetic tape storage is external.

Baltimore & Ohio Railroad Company	
Media	Speed
1400 Output Converter	800 lines/min
1300 Output Converter (Modified IBM 407)	150 lines/min
1300 Output Converter (Modified IBM 519)	100 cards/min
First National Bank of Boston	
Printed Page (160 characters/line, 2 printers)	900 lines/min
Printed Page (120 characters/line, 1 printer)	150 lines/min
Cards	100 cards/min
Michigan Hospital Service	
Magnetic Tape	60,000 digits/sec
Printed Page	900 lines/min
Anelex high speed printer at 120 char/line.	
Minneapolis-Honeywell Regulator Co.-TCG Division	
Printed Page	900 lines/min
Printer has 120-160 char/line, 55 characters	
Printed Page	150 lines/min
Printer has 120-120 char/line, 47 characters	
Cards	100 cards/min
Treasury Department	
Magnetic Tape	60,000 dec dig/sec
Punched Card	100 cards/min
Printed Page	900 lines/min

The output of the central processor is on magnetic tape only. The data on the tape is printed and/or punched "off line".

INPUT

Manufacturer	
Media	Speed
Punched Cards	900 cards/min (Input Converter)
Paper Tape	10 char/sec (via console)
Keyboard	Manual (via console)
Magnetic Tape	60,000 dec dig/sec (On line tape units)
Baltimore & Ohio Railroad Company	
Cards (1200 Input Converter)	900 cards/min
First National Bank of Boston	
Punch Cards	900 cards/min
Paper tape is to be added.	
Michigan Hospital Service	
Cards	900 cards/min
Magnetic Tape	60,000 dig/sec
Input is via card reader to magnetic tape to central processor.	
Minneapolis-Honeywell Regulator Co.-TCG Division	
Punched Card	900 cards/min
Card editing is possible.	
Treasury Department	
Paper Tape (Flexowriter)	60 char/min
Cards	900 cards/min
Card data is converted on magnetic tape. Magnetic tape is input to central processor at 60,000 decimal digits/sec.	
One reel of tape is 2,700 feet long, 3 inches wide, and can store 37,200,000 decimal digits or 28,200,000 alphabetic characters. Input to the system is punched cards; input to the central processor is magnetic tape or paper tape.	

OUTPUT

Manufacturer	
Media	Speed
Punched Cards	100/min (Output Converter)
Printing	900 lines/min (Output Converter)
Paper Tape	10 char/sec (via console)
Magnetic Tape	60,000 dec dig/sec (On line tape units)
Character-at-a-Time	10 char/sec (Console Typewriter)
Paper Tape	Input Converter
Paper Tape	Output Converter

CIRCUIT ELEMENTS OF ENTIRE SYSTEM

Manufacturer	
Tubes	3,600
Tube types	Type 6145 and other computer quality types
Crystal Diodes	60,000
Magnetic Cores	117,000
Transistors	500
The above figures are for the Central Machine.	
Separate Cabinets	10 Types (building block units)
Size of installation is dependent on application.	
Up to 100 magnetic tape units may be used in on-line operation.	

CHECKING FEATURES

Manufacturer	
Every word contains checking digits. Transfer weight count check. Arithmetic weight count check. Special circuit checking. Selection and order verification checking.	
Blank column and multiple punch column detection is under control of the operator of the Input Converter.	
Marginal checking circuitry included in addition to the above.	

POWER, SPACE, WEIGHT, AND SITE PREPARATION

Manufacturer			
Power, computer	94.6 Kw	110 KVA	0.86 pf
Power, air cond.	49.2 Kw	60 KVA	0.82 pf
Area, computer	550 sq ft		
Floor loading	Less than 125 lbs/sq ft		
Weight, computer	70,000 lbs		
Air conditioner is built in. No user requirements.			
The above weight and power figures include 10 magnetic tape installations. Space figure excludes aisles and work areas. The total is 4,500 sq ft.			

The clear space to ceiling is 8 ft. 3 in.
Recommended floor space 40 by 100 feet (for minimum installation).

Voltage requirements - 208 volts, 3 phase, 60 cycle.

Baltimore & Ohio Railroad Company

Power, computer 230 KVA
Volume, computer 67,500 cu ft
Area, computer 7,500 sq ft
Floor loading 60 lbs/sq ft
50 lbs/sq ft

Weight, computer 123,000 lbs

Site is prepared with perforated metal false ceiling. Plenum between false and building ceiling, false floor - 2 ft x 4 ft sections made of aluminum honeycomb, power distribution units supplied by manufacturer. Air conditioning (chilled water) installed for 70°F. ± 2°F.

First National Bank of Boston

Power, computer 160 Kw 200 KVA 0.8 pf
Power, air cond. 40 Kw 44 KVA 0.9 pf
Volume, computer 6,065 cu ft
Volume, power room 825 cu ft
Volume, air conditioner 60 cu ft
Area, computer 945 sq ft
Area, power room 200 sq ft
Area, air conditioner 20 sq ft
Room size, computer 5,025 sq ft
Room size, power room 600 sq ft
Room size, air condition 95 sq ft
Floor loading 22 lbs/sq ft

125 lbs concen max

35 lbs/sq ft power room

Capacity, air conditioner 15 Tons

Weight, computer 170,300 lbs

Weight, power room 22,000 lbs

Weight, air conditioner 3,065 lbs

Site preparation included a 15-ton air conditioner for magnetic tape room (including circulating water supply), false floors and partitions for three rooms (MFU, CPU, and converters) and an independent power supply.

Michigan Hospital Service

Power, computer 184 Kw 200 KVA 0.8 pf
Volume, computer 5,700 cu ft
Area, computer 4,450 sq ft
Floor loading 24 lbs/sq ft
710 lbs concen max

Capacity, air conditioner 64 Tons

Weight, computer 106,400 lbs

Air conditioning system packaged units include 35 tons built into computer, 16 tons for Tape File Room, 8 tons for High Speed Printer and Personnel, and 5 tons for Personnel in Central Processor.

The site has a dropped metal pan ceiling with sound proof bats in each pan. This ceiling is not used as an air condition plenum. The building is of steel and concrete construction. Power for the Data Processor is located on the roof of the building together with the motor generators, electrical panels, compressors, vacuum pump, and individual water tower. The compressors are situated on the 6th floor of the building. Power, water, and air lines come from the 8th floor to the ceiling of the 5th floor. All such lines are suspended from the ceiling of the 5th floor and stub up through the concrete floor wherever necessary to feed the individual units. A free floor was designed and installed to cover all signal wires. Air conditioning is by package units which feed through ducts above the pan ceiling to various outlets. Package air conditioning units are equipped with steam to be used for either heating or humidity control.

Minneapolis-Honeywell Regulator Co.-TCG Division

KVA, computer 200
Volume, computer 62,000 cu ft
Area, computer 5,900 sq ft
Room size 5,900 sq ft
Floor loading 125 lbs/sq ft
40 lbs concen max

Capacity, air conditioner 35 Tons

Weight, computer 110,000 lbs

Each unit is self cooled. False ceiling is installed for appearance. Power central setup to provide stable power. Power is 208 volts, 3 phases, 4 wire, 60 cycles.

Treasury Department

Power, computer 170.44 Kw 213.05 KVA 0.80 pf 208V.
Volume, computer 9,751 cu ft
Volume, air conditioner 891 cu ft
Area, computer 1,513 sq ft
Area, air conditioner 270 sq ft
Room size 8,400 sq ft
Floor loading 101 lbs/sq ft

267 lbs concen max

Capacity, air conditioner 45 Tons

Weight, computer 153,250 lbs

Total includes built in air conditioning

Weight, air conditioner 8,175 lbs

Total includes 3 separate air conditioning units

Site preparations were made at the time the building was erected. The building is of brick and concrete construction with steel girders and concrete floors. Special features in the area include: false flooring; glass enclosures for the input-output converter room, central processor room, magnetic file room, and engineers' room; inter-com system between four areas; dehumidifiers in the magnetic file room; air and water ducts; acoustical tile ceiling for all rooms; power ducts to all rooms from central power room; and air conditioning for the area.

COST, PRICE AND RENTAL RATES

Baltimore & Ohio Railroad Company

1 Model 1000 Central Processor	\$21,500/mo.
12 Model 1100 Magnetic File Units	10,800/mo.
3 Model 1170 File Switching Units	570/mo.
1 Model 1200 Input Converter, with card reader	3,325/mo.
1 Model 1300 Output Converter	1,800/mo.
1 Model 1400 Output Converter, including high speed printer	3,500/mo.
1 Model 1900 Central Power	1,750/mo.
	<u>\$43,245/mo.</u>

Additional equipment includes IBM 407 at \$800/month and IBM 519 at \$944/month.

First National Bank of Boston

For the equipment listed, the total monthly rental is \$43,475.

Michigan Hospital Service

	Monthly Rental
One Central Processor	\$21,500
Eight Magnetic Tape Units	7,200
One Card Reader and Input Converter	3,325
One File Reference Unit	550
One Output Converter and High Speed Converter	3,500
(Including maintenance)	<u>\$36,075</u>

Minneapolis-Honeywell Regulator Co.-TCG Division

Quantity	Model	Unit	Purchase Price	Monthly Rental One Shift
1	1000	Central Processor including High-Speed Memory Arithmetic-Control Units Input and Output Buffers Read-Write Unit Central Console Unit Air Conditioning		
11	1100	Magnetic File Unit including Amplifier Unit	\$985,000	\$21,500
2	1170	File Switching Unit	660,000	14,850
1	1200	Card Input System including 900-card-per-minute Card Analyzer and Converter Control Unit	19,200	380
1	1300	Output Converter Control Unit	185,000	3,325
1	1310	Adapter for 150-line-per-minute printer (used with Model 1300 Output Converter Control Unit)	100,000	1,800
1	1320	Adapter for 100-card-per-minute punch (used with Model 1300 Output Converter Control Unit)	13,000	200
1	1400	Output Printing System including 900-line-per-minute printer and Converter Control Unit	1,900	35
			<u>215,000</u>	<u>4,300</u>
		Total	\$2,179,100	\$46,390

Maintenance service contract is \$20,000 month (Purchased).

Treasury Department
Installation of the DATAmatic System \$87,777
Components:

Central Processor
Auxiliary Central Processor
16 Magnetic File Units
4 File Switching Units
3 Card Input Systems
Converter Control Unit, Low Speed
IBM 519 Summary Punch
Output Printing System, High Speed
Power Room installation and equipment
Cost of False Flooring
Approximate Installation Cost

176 Hours, Basic Monthly Rental Charge:
Central Processor \$21,500
Auxiliary Central Processor 3,900
16 Magnetic File Units at \$1,350 21,600
4 Switching Units at \$190 760
3 Card Input Systems at \$3,325 9,975
Converter Control Unit, Low Speed 535
IBM 519 Summary Punch 144
Output Printing System, High Speed 4,300
Basic Monthly Rental \$62,714

Excess Use Time per Month:
Central Processor at \$61.08/hour \$20,161.80
Auxiliary Central Processor at \$11.08/hour 3,711.80
16 Magnetic File Units at \$3.84/hr 6,566.40
4 Switching Units at \$.54/hour 115.56
3 Card Input Systems at \$9.45/hour 132.30
Output Printing System at \$12.22/hr 2,566.20
Average Excess Use Time Cost per Month \$33,254.06
Basic Cost \$62,714.00
Excess Use Time Cost 33,254.06
Total Approximate Monthly Cost \$95,968.06

System maintenance and service are included in the monthly rental charge. Power room maintenance and service are covered under a separate contract which averages \$4,000 annually.

PERSONNEL REQUIREMENTS

Baltimore & Ohio Railroad Company
One 8-Hour Shift

Supervisors 5
Analysts and Programmers 35
Librarians 1
Operators 4

Operation tends toward closed shop.
Methods of training used includes a combination manufacturer's formal sessions and informal on-job training.

First National Bank of Boston
One 8-Hour Shift

Supervisors 1
Analysts 5
Programmers 11
Coders 2
Clerks 3
Operators 2
In-Output Oper 6
Tape Handlers 2

Methods of training used includes 4 weeks in manufacturer's school and on-the-job training.
Michigan Hospital Service

One 8-Hour Shift
Supervisors 1
Analysts 3
Programmers 12
Clerks 2
Operators 1
In-Output Oper 2
Tape Handlers 1

Operation tends toward open shop.
Methods of training used includes programming training by Minneapolis-Honeywell and operator training by Michigan Hospital Service (detailed operating instructions).

Minneapolis-Honeywell Regulator Co.-TCG Division

	One 8-Hour Shift	Two 8-Hour Shift	Three 8-Hour Shift
Supervisors	1	1	1
Programmers	17	17	17
Clerks	4	4	4
Librarians	1	1	1
Operators	2	4	5
Engineers	3	5	7
In-Output Oper	2	4	6
Tape Handlers	1	2	3

Operation tends toward open shop.

Methods of training used

Six weeks programming course for analysts and programmers.

Operation 3 weeks on-the-job

Console 6 weeks on-the-job

Treasury Department

	One 8-Hour Shift		Two 9-Hour Shifts	
	Used	Recomm	Used	Recomm
Supervisors	2		4	
Analysts	2	3	-	
Programmers	14		-	
Coders	-		-	
Clerks	6		3	
Librarians	1		2	
Operators	-		5	6
Engineers	-		-	
Technicians	1		-	
In-Output Oper	-		8	8
Tape Handlers	-		4	6

Operation tends toward open shop.

One DATAmatic representative is assigned full time for guidance in the programming activities and the operations of the system. Periodically, special training courses are conducted by the DATAmatic Corporation either at the site or company location. On-the-job training is given continuously to peripheral equipment and console operators.

Personnel listed under the two 9-hour shifts are assigned to the Electronic Data Processing Section which is responsible for the scheduling of machine time and operation of the electronic equipment. Programming is one of the activities of the Methods and Procedures Section. This staff performs all planning, programming and checking out of the routines to place them in an operational state and provides all operating instructions necessary for successful performance. This group of employees operates on an 8-hour basis but each individual programmer is on 24-hour call.

RELIABILITY, OPERATING EXPERIENCE, AND TIME AVAILABILITY

Baltimore & Ohio Railroad Company

Good time 42.3 Hours/Week (Average)
 Attempted to run time 45 Hours/Week (Average)
 Operating ratio (Good/Attempted to run time) 0.94
 Above figures based on period Feb 60 to Mar 60
 Passed Customer Acceptance Test Mar 59
 Time is available for rent to qualified outside organizations.

First National Bank of Boston

Good time 39.5 Hours/Week (Average)
 Attempted to run time 40 Hours/Week (Average)
 Operating ratio (Good/Attempted to run time) 0.98+
 Above figures based on period Jul 58 to 31 Mar 60
 Passed Customer Acceptance Test Jul 58
 Time is available for rent to qualified outside organizations.

Time is rented to Datamatic Service Bureau (1 full shift).

The operating ratio is approximately the same for the Service Bureau.

Michigan Hospital Service

Average error-free running period 4.9 Hours
 Good time 53.3 Hours/Week (Average)
 Attempted to run time 58.2 Hours/Week (Average)
 Operating ratio (Good/Attempted to run time) 0.916
 Above figures based on period 1 Jan 60 to 6 Aug 60
 Passed Customer Acceptance Test 1 Mar 58
 Time is available for rent to qualified outside organizations.

Use by outside organizations is arranged through Minneapolis-Honeywell Regulator Company, DATAmatic Division.

Minneapolis-Honeywell Regulator Co.-TCG Division
 Good time 92 Hours/Week (Average)
 Attempted to run time 100 Hours/Week (Average)
 Operating ratio (Good/Attempted to run time) 0.92
 Above figures based on period 1 Jul 59 to 1 Jul 60
 Passed Customer Acceptance Test 1 Jul 59
 Time is not available for rent to outside organizations.

Treasury Department

Average error-free running period 8.2 hours per 9 hour shift
 Good time 115 Hours/Week (Average)
 Attempted to run time 126 Hours/Week (Average)
 Operating ratio (Good/Attempted to run time) 0.913
 Above figures based on period 1 Apr 60 to 30 Jun 60
 Passed Customer Acceptance Test 1 Nov 58
 Time is not available for rent to outside organizations.

The operating ratio is based on a 7 day week, two 9-hour shifts a day.

ADDITIONAL FEATURES AND REMARKS

Baltimore & Ohio Railroad Company

Adopted procedures for magnetic tape labelling, storage, shipping, and protection from humidity, temperature and physical, electrical, fire, or other damage include generation of labels in computer program used for tape assignment, tape storage in closed file-type cabinets, and air-conditioned atmosphere for humidity and temperature control.

First National Bank of Boston

Outstanding features include exceptional reliability, very high error-free recording, and recovery of information on magnetic tapes. Unique system advantages include high capacity of tapes, 465,000 punched cards per tape (reel), high speed, simultaneous read/write (60,000 digits/sec.), and ability to edit on off-line converters, saving CPU time.

Michigan Hospital Service

Outstanding features include large storage capacity of magnetic tape (37,200,000 digits per reel), read/write magnetic tape at 60,000 digits per second, and three address instruction system (simplifies programming).

Unique system advantages include system and instructions designed for data processing, particularly for low activity updating of large record files.

Tape reels are numbered with ink marking pen. Data is labelled with Labelon Tape. Tape room is controlled for temperature, humidity, and dust. Security Tapes are stored in first floor lobby for 24 hour period. Security Tapes are alternated in warehouse storage on a semi-monthly basis.

Minneapolis-Honeywell Regulator Co.-TCG Division
Outstanding features include 3" wide tape, orthotron-
ic control, 900 lines per minute printing speed.
Tape storage is dust, humidity and temperature con-
trolled. A distant vault is used for backup tapes.

Treasury Department

Outstanding features are (1) Transfer rate of
60,000 decimal digits per second; (2) efficient and
speedy sorting; (3) searches 10 tapes at once at
transfer rate of 600,000 decimal digits; (4) "OFF
LINE" input and output; (5) built in air condition-
ing for central processor.

Unique system advantages include (1) ability to
read and search forward and backward and (2) Modulo
9 weight count checking system.

Adopted procedure for magnetic tape labelling,
storage, shipping and protection from humidity, temp-
erature and physical, electrical, fire, or other
damage include:

Tape Labelling

Reels are labeled with color code, name and
run number(s). Dates, names and run codes are written
on tape.

Storage

Active tape records are stored on shelves in
the Magnetic File area. Security tapes are stored
in a vault in another building.

Shipping

Reels are placed in plastic bags and boxed in
corrugated cartons cushioned with fillers.

Protection from Humidity, Temperature, etc.

Air conditioning and normal protection.

The tape utilized in this System is divided into
36 linear recording channels. 31 of these channels
are used for storing information. All other channels
are used for control purposes. Data is arranged
along the 31 information channels in arbitrary units
called words and blocks. Each block contains a total
of 62 information words. There are 52 bits in a
word. Four are used for checking purposes and the
remaining 48 may represent either numeric or alpha-
betic data. A word may be made up of 12 four-bit
decimal digits, 8 six-bit alphabetic characters or
any combination of these adding up to 48 binary
digits.

FUTURE PLANS

First National Bank of Boston

There is a tentative plan to switch to Honeywell
H-800 in 1962, when a third high-speed printer, a
high-speed paper tape input, and high-speed MICR
input (2 systems) will be added.

Treasury Department

Present plans are to carry out the program relating
to punch card U. S. Savings Bonds established at the
inception of the system, all available machine time
is required. Plans are in a formulative stage to
include the processing of Series E paper bond re-
tirements and reissue transactions as machine time
is made available through improved programming tech-
niques and liquidation of the backlog which ante-
dates installation of the equipment.

INSTALLATIONS

The Baltimore and Ohio Railroad Company
B&O Central Building
Baltimore 1, Maryland

The First National Bank of Boston
67 Milk Street
Boston, Massachusetts

Michigan Hospital Service
441 E. Jefferson
Detroit 26, Michigan

Minneapolis-Honeywell Regulator Co.-TCG Division
2753 4th Avenue South
Minneapolis 8, Minnesota

Datamatic Division
Minneapolis-Honeywell Regulator Company
60 Walnut Street
Wellesley Hills, Massachusetts

Treasury Department
Bureau of Public Debt
214 Seventh Street
Parkersburg, West Virginia

DE 60

Clary Model DE 60 Computer

MANUFACTURER

Clary Corporation

APPLICATIONS

System is designed for general purpose, scientific, engineering, commercial, on-line, and real time uses.

PROGRAMMING AND NUMERICAL SYSTEM

Internal number system Binary Coded Decimal
 Decimal digits/word 18 and sign
 System is externally programmed.
 Instructions decoded 37
 Arithmetic system Fixed point (to right of word)
 Instruction type Multiple address (up to five) and multiple operations/instruction
 Number range Less than 10^{18} and equal to or greater than 0.

Photo by Clary Corporation

Instruction word format

Source	Operation	Destination	Format (Output)
(one source)	(up to four)	(up to four)	Print, Word Length, Decimal Point

Automatic built-in subroutines are contained in a plug-in cartridge. Any standard function ($\sqrt{\quad}$, sin, cos, e^x , etc.) may be obtained. Special subroutines are furnished to customers' specifications.

Registers include multiplicand, dividend, quotient, remainder, registers and a special register to retain last operand used.

ARITHMETIC UNIT

Operation	Incl Stor Access Microsec	Exclud Stor Access Microsec
Add	60,000	3,000
Mult	200,000 (Avg)	140,000
Div	220,000 (Avg)	160,000

Time includes access to 5 addresses and automatic alignment (shifting) of decimal point.

Arithmetic mode	Serial
Timing	Synchronous
Operation	Sequential

Photo by Clary Corporation

STORAGE

	No. of Words	No. of Digits	Microsec
Medium			
Drum	32	576	7,500 (Avg)
Capacity may be expanded to 160 words (5120 digits) in units of 16 words. Access time will be unchanged.			

Photo by Clary Corporation

INPUT

Media	Speed
Keyboard	Manual
Paper Tape	20 char/sec
Punched Cards	20 col/sec
On-line Equipment	

Except for Keyboard, above equipment is optional or engineered to meet requirements.

OUTPUT

Media	Speed
Printer	20 char/sec 10 char/line
Typewriter	10-15 char/sec
Paper Tape	20 char/sec
Punched Cards	20 col/sec

Speeds are limits of peripheral equipment, not the computer. Except for Printer, above equipment is optional.

CIRCUIT ELEMENTS OF ENTIRE SYSTEM

Type	Quantity
Tubes	
Thyratrons	14
Diodes	2,000
Transistors	200

POWER, SPACE, WEIGHT, AND SITE PREPARATION

Power, computer	0.15 Kw
Volume, computer	76.5 cu ft
Area, computer	25.5 sq ft
Room size	8 ft x 8 ft
Weight, computer	300 lbs

Photo by Clary Corporation

PRODUCTION RECORD

Number produced to date	9
Number in current operation	9
Number in current production	10
Number on order	8
Anticipated production rates	4 - 10 months
Time required for delivery	3 Months

COST, PRICE AND RENTAL RATES

Description and Price
Standard Clary Computer Model DE-60

1 Arithmetic center - 6102 and 6202
1 Input - 6302
1 Output - 6402
1 Desk - 6602.01 and 6702.01
1 Programmer - 6502.01 (including one cartridge of customer's choice)
2 Plugboards with wires - 6802
\$18,000.00 ex-factory San Gabriel, plus all applicable taxes.
90 days delivery, unless otherwise provided.

Optional and Additional Equipment
IBM or Remington Rand typewriter output (20" carriage standard) in lieu of standard output 6402, \$2,000.00
Punch Tape output (in addition to standard output 6402), \$2,000.00
Additional standard cartridges \$45.00 (Square root, log, antilog, power series, sin, cos, plus others as they become available).
Custom cartridges \$2.50 per step.
90 days delivery for typewriter equipped models.

Contract Terms

Purchase Plan

Prices are ex-factory San Gabriel, plus all applicable taxes.

Ninety (90) day free service and parts warranty.

After first 90 days, service contract available as follows:

Within 50 miles of service facility 3% of purchase price per year, plus parts.

Over 50 miles from service facility 3% of purchase price per year, plus actual round trip travel expense, plus \$10.00 per hour for time actually spent by each member of service group to and from location, plus parts.

Lease Plan

Minimum lease period contract three (3) years.
Monthly lease price, payable in advance, 3 1/2% of purchase price per month, including service. Ninety day warranty from installation date for parts. If unit is located over 50 miles from service facility, customer pays actual round trip mileage additional, plus \$10.00 per hour for time spent by each member of service group for travel time to and from location.

After three (3) year initial period, lease may be renewed annually as follows:

1. Within 50 mile radius of service facility, 1% of purchase price per month, including service plus parts.
2. Over 50 mile radius, 1% of purchase price per month plus actual round trip mileage, plus \$10.00 per hour for actual time spent by each member of service group traveling, plus parts.

Rental Plan

Minimum rental period twelve (12) months.
Monthly rental is 3% of purchase price per month, payable in advance, including service and parts if located within 50 mile radius of service facility. If located over 50 miles from service facility, customer pays actual mileage expense of service personnel, plus \$10.00 per hour per man for time spent traveling to and from location.

Sixty (60) day minimum cancellation notice required after contract period expires.

In the event customer elects to purchase within two years after renting, 50% of first year's rental and 40% of second year's rental may be applied toward the purchase price.

PERSONNEL REQUIREMENTS

System may be used for "open shop" operation with no permanent personnel assigned.

Training made available by the manufacturer to users includes programming and operating instruction at no charge. A two week maintenance and repair course is given at no charge. A six week maintenance and repair course is given at a charge of \$600.

Photo by Clary Corporation

RELIABILITY, OPERATING EXPERIENCE, AND TIME AVAILABILITY

System features and construction techniques utilized by the manufacturer to insure required reliability includes modular construction, and plug-in components. Experience shows 96.5% - 99.9% uptime.

ADDITIONAL FEATURES AND REMARKS

System is easy to use and program, may be used manually as a high speed calculator or under automatic control. Large words for high accuracy are used. Completely decimal with no conversion routines necessary, small size and low power requirements (150 watts), and no cooling are additional features. System is complete and small enough to fit right into an office without special site preparation. Computation may then be done by the originator at his location.

DIANA

LIFE Diana Computing System

MANUFACTURER

Laboratory for Electronics, Incorporated

APPLICATIONS

System is designed for general purpose business applications.

PROGRAMMING AND NUMERICAL SYSTEM

Internal number system	Binary coded decimal
Decimal digits/word	Variable word and block length
Decimal digits/instruction	10
Instructions per word	1
Instructions decoded	20
Arithmetic system	Fixed point
Instruction type	Two address (Source and destination)
Number range	Alphanumeric: 0 to 99 characters per word for computing up to 12 places
Instruction word format	

V	W	X	Y	Z	D	d	O	P	(sign)
---	---	---	---	---	---	---	---	---	--------

ARITHMETIC UNIT

	Incl Stor Access Microsec	Exclud Stor Access Microsec
Add	560	186
Mult	3,137	2,577
Div	4,830	4,270

Construction (Arithmetic unit only)

Magnetic Cores	
Arithmetic mode	Parallel
Timing	Synchronous (Excepting File Drums)
Operation	Sequential and Concurrent

The operation times given above for addition and multiplication are for the number 999,999 as operands. The divide time is for a 5 digit quotient. Computer operations are mainly sequential. Input-output operations are concurrent with computation. The arithmetic unit may also work concurrently with non-arithmetic operations. Non-arithmetic operations may be performed concurrently during the last 113 microseconds of the addition time, during the last 2,265 microseconds of multiplication, and during the last 3,966 microseconds of division.

The arithmetic unit consists of the product, multiplier, and multiplicand registers. These registers are 13 digits in length, with character position 0 holding the sign and character position 12 holding the most significant character.

Since the system is capable of handling British sterling notation, the adder, which is part of the arithmetic unit, operates in sterling notation if digit d of the addition, subtraction, multiplication, and round instructions is not a zero. In this case, scale of 10 operation is specified. Multiplication is accomplished by halving the multiplier and doubling the multiplicand, with the contents of the multiplicand register being added to the contents of the product register each time the number in the multiplier is odd. On the whole, this method of multiplication is faster than one involving successive additions. Division is accomplished by repeated subtraction of the divisor from the dividend, with the dividend initially in the multiplicand register and the divisor in the multiplier register. The

quotient appears in the multiplicand register and the remainder in the product register.

STORAGE

Media	No. of Words	No. of Digits	Access Microsec
Magnetic Core	Variable	200 - 10,000	34
Hi-Speed Drum	Variable	58,500	11,000
File Drums	Variable	(1.875-652) x 10 ⁶	197,000
Magnetic Tape			

Access times given above include drum switching. The high speed drum rotates at a speed of 100 revolutions per second, recording is performed in parallel and includes 6,000 characters of input-output buffers.

The file drum rotates at 3 revolutions per second, recording is serial. Each file drum has a capacity of 15 x 10⁶ bits. Characters may be alphanumeric or numeric only. The magnetic file drum is the bulk storage medium. It is 15 inches in diameter by 15 inches long, having a capacity of 1,875,000 alphanumeric characters or 2,500,000 numeric characters. Any number of these file drums (up to a maximum of 330) can be used in a given installation, and regardless of how many are used, the average random access time to any part of the entire file remains one-sixth of a second. For intermediate and buffer storage a single high-speed drum is used, having a capacity of 58,500 alphanumeric characters and an average random access time of 10 milliseconds.

Internal working storage (OAST) consists of from 200 to 10,000 characters of magnetic core storage with an average access time of 34 microseconds. In addition, there are twelve transfer registers, each with magnetic core storage for 10 alphanumeric characters.

Since the storage capacity of the magnetic file drums and of OAST is scalable, a user need acquire only the capacity required by his application. This factor, together with a choice of the type and quantity of input and output devices, provides a flexible system that can be tailored to the individual requirements of any given application.

File drums are grouped into units of from one to 33 drums per unit (actually from 300 to 10,000 tracks per unit, which, at 300 tracks per drum, would be a maximum of 33 1/3 drums per file drum unit.) The maximum number of file drum units in a given installation is 10. Both the number of file drums per unit and the number of units are determined by the requirements of the application for which the system is intended.

Each file drum unit contains its own reading and writing mechanism and track selection devices. In locating a record in a file drum unit the computer must first select the proper track by placing the track number in the track address register. The track number may be wholly contained in the record number (tag), or it may be found on an index track which relates record numbers to the appropriate track numbers.

Transfers from a file drum unit can be in the form

of a block transfer to OAST, or a word or character transfer to the arithmetic unit or one of the transfer register. Multiple-block transfer to OAST are also possible, provided OAST is large enough. Information can be transferred from one file drum unit to another, a track at a time. If the installation includes a magnetic tape unit, information can also be transferred from a file drum unit to tape, a track at a time.

Information can be written on the file drum in only three ways: by a block transfer from OAST, by a track transfer from another file drum unit, or by a track transfer from magnetic tape. During track transfers in either direction, the computer may perform other operations which do not require the use of the drums. The time required for a track transfer is 0.6 second. One drum, therefore, can be loaded or unloaded in three minutes.

On the file drums, information is stored in serial by bit fashion. On the magnetic tape it is stored in parallel by bit, serial by character fashion. The high speed drum serves as an intermediate speed general storage for the computer and in addition contains the input-output buffers. This drum sets the system pulse repetition frequency of 150 kc by means of an engraved clock track. A second clock track is used in locating sectors on the drum. This sector clock track has 20 equal divisions which are used to locate the 20 sectors of any given band. The use of bands (adjacent tracks in groups of 7) permits parallel by bit handling of handling of characters and a 150 kc frequency. The capacity of this drum can be specified for each system arrangement.

Magnetic Core Storage (OAST, Transfer Registers)
OAST has a maximum size of 10,000 characters arranged into 100 sectors of 10 decades per sector, 10 characters per decade. Its minimum size is two sectors or 200 characters. Information is located by sector, decade, and character position, or by sector and word number. Data is handled in parallel by bit, serial by character at a character frequency of 150 kc. The maximum access time to any characters is 9 bit times or 60.3 microseconds (the time required to move from the first to the last character in a decade.)

Information recorded in OAST wipes out the previous characters, while that read from OAST is retained in storage by recirculation of the characters. In a single-block transfer to OAST, the most significant character of the block transferred is placed in the zero position of the decade addressed. In a multiple-block transfer to OAST, the most significant character of the first block transferred is placed in the zero position of the decade addressed; following blocks are written densely. The number of blocks to be transferred is specified in the instruction.

INPUT

Media	Speed
Paper Tape	300 char/sec
Typewriter	Manual

OUTPUT

Media	Speed
Paper Tape	60 char/sec
Line Printer	150 lines/min ICT 915

Many different types of input-output equipment may be used simultaneously, each working concurrently with the others and with the computer.

Information to be processed or stored can be entered into the system in a number of different ways; via punched paper tape, punched cards, direct keyboard or in certain cases, via magnetic tape. Output can be via punched paper tape, punched cards, line printer, direct typewriter cathode ray tube viewer, or in certain cases, magnetic tape. The magnetic tape input and output units are more in the nature of drum loading and unloading devices; they are used chiefly to store information to which random access is not currently required, or to provide duplicate storage for security purposes. The International Computers Tabulators Model 915.

CIRCUIT ELEMENTS OF ENTIRE SYSTEM

Type	Quantity
Tubes	
8 types	1,300
Diodes	
6 types	62,000
Magnetic Cores	
2 types	15,000

Above information is based on the ICT computer

CHECKING FEATURES

Single bit errors are detected in all information and control paths except in the arithmetic unit. This includes input-output paths, and all data on the addressed file drum track.

Dual (parallel) arithmetic unit. If the dual arithmetic unit is not included, arithmetic operations can be checked by program.

POWER, SPACE, WEIGHT, AND SITE PREPARATION

Power, computer	90 Kw
Volume, computer	12,000 cu ft
Area, computer	1,200 sq ft
Room size	30 ft x 40 ft
Floor loading	200 lbs/sq ft
	250 lbs concen max
Weight, computer	20,000 lbs
	3 phase, 115V ac, 60 cycles/sec.

PRODUCTION RECORD

Number produced to date 1

INSTALLATIONS

This computer is now installed operating at The International Computers Tabulators, facilities in England.

DIGITRONIC CONVERTER

Digitronics Converter Data Processor

MANUFACTURER

Digitronics Corporation

APPLICATIONS

System is designed for data conversion from magnetic tape to paper tape or vice versa, or from one magnetic tape to another, with numerous editing and format control operations.

PROGRAMMING AND NUMERICAL SYSTEM

Internal number system	Binary Coded Decimal
Timing	Asynchronous
Operation	Sequential

System is plugboard programmed. Code translation is possible from any 6-bit to any other 6-bit code. Selective translation is based on character position in a message or on the column splits. Automatic zero suppression and insertion of editing characters may be performed as required. There is data-con-

Photo by Digitronics Corporation

trolled selection of alternative outputs and a provision is made for grouping several input messages into one output message or vice versa.

STORAGE

Media	No. of Char	Access	Microsec
Core Matrix	Up to 1,024		20
Magnetic Tape			
No. of units that can be connected			2 Units
No. of chars/linear inch of tape			200 Chars/inch
Channels or tracks on the tape			8 Tracks/tape
Tape speed			75 Inches/sec
Transfer rate			15,000 Chars/sec
Start time			5 Millisec

Stop time 5 Millisec
 Tape units normally furnished have above characteristics and handle IBM or Univac compatible tape. Optional provision for control of Uniservo or IBM high density tape units.

INPUT

Media	Speed
Magnetic Tape	15,000 char/sec
Compatible with IBM, Univac, or other specified system	
Punched Paper Tape	1,000 char/sec
Reel/strip or strip only	

OUTPUT

Media	Speed
Magnetic Tape	15,000 char/sec
Compatible with IBM, Univac, or other specified system	
Punched Paper Tape	100 char/sec
Using Teletype punch	
Punched Paper Tape	240-300 char/sec
Using Soroban punch	
Two or more output units can be provided with selection controlled by first character of message through plugboard.	

CIRCUIT ELEMENTS OF ENTIRE SYSTEM

Type	Use
Diodes	
General Transistor	
DX2, DX3	All logic circuits
Transistors	
GT1170	For amplification. These
1228	three types account for over
1229	95% of all transistors used.

CHECKING FEATURES

Input magnetic tape parity check with automatic re-read, output memory parity check, and input paper tape parity check, if applicable, are among the checking features. An output magnetic tape read-after-write check is optional.

POWER, SPACE, WEIGHT, AND SITE PREPARATION

A 30 amp, 115 volts, 60 cycle, power outlet is required.

PRODUCTION RECORD

Number produced to date	3
Number in current operation	3
Number on order	2
Time required for delivery	6 - 7 months

PERSONNEL REQUIREMENTS

One technician is required per 8-hour shift. Training made available by the manufacturer to the user includes maintenance training.

ADDITIONAL FEATURES AND REMARKS

There is a wide choice of editing features, all plugboard controlled. The system relieves a general purpose computer of the necessity for communication with any medium slower than magnetic tape, and handles large proportion of the input and output editing.

DISTRIBUTAPE

Distributing Tape Computer

MANUFACTURER

Litton Industries
Monroe Calculating Machine Division

APPLICATIONS

Distributape was designed as a special purpose computer to sort and summarize at high speed unit record information which has been recorded in the medium of punched paper tape. This computer finds application in those areas where source data can be recorded on punch tape--such data being recorded in random sequence and whose subsequent processing requires sorting and summarizing for use in statistical or financial reports.

PROGRAMMING AND NUMERICAL SYSTEM

Internal number system	Binary
Arithmetic system	Fixed point
Number range	0 to $\pm 10^{11}$

Programming is controlled partially by instructions contained in input tapes and partially by control switch selection.

Photo by Monroe Calculating Machine Division

ARITHMETIC UNIT

Construction (Arithmetic unit only)		
Vacuum-Tubes	Type 5965	130
Diodes	Type 1N636	1,700
Arithmetic mode	Serial	
Timing	Synchronous	
Operation	Sequential	

STORAGE

Medium	No. of Words	Access
Magnetic Drum	1,000	Microsec
		8,000

Access time is average.

INPUT

Medium	Speed
Paper Tape	235 char/sec

OUTPUT

Medium	Speed
Paper Tape	17 char/sec

CIRCUIT ELEMENTS OF ENTIRE SYSTEM

Type	Quantity
Tubes	
Primarily 5965	150
Diodes	
Primarily 1N636	1,964
Transistors	64

CHECKING FEATURES

Checking features include a paper tape parity check, a proof total balance check, and an instruction code sequence check.

POWER, SPACE, WEIGHT, AND SITE PREPARATION

Power, computer	2 Kw
Volume, computer	45 cu ft
Area, computer	9 sq ft
Room size	300 sq ft
Floor loading	50 lbs/sq ft
Weight, computer	450 lbs

Utilities required is one 30 amp service outlet, 115 volts, AC, 60 cycles.

PRODUCTION RECORD

Number produced to date	3
Number in current operation	2
Time required for delivery	6 months

COST, PRICE AND RENTAL RATES

The Distributape Computer and the Model 135 Printer are available at a total cost of \$45,000 or a monthly rental of approximately \$1,250.

Service contracts are available for customer owned machines at \$2,000/year. Rental contract prices include service.

PERSONNEL REQUIREMENTS

System requires 1 operator for each 8-hour shift. Training is made available by the manufacturer to the user.

RELIABILITY, OPERATING EXPERIENCE, AND TIME AVAILABILITY

Operating experience with two machines currently in use indicates that usable computer time as a percentage of operating time can be maintained at 95 per cent or higher.

ADDITIONAL FEATURES AND REMARKS

Address selection and sort control feature permits a rapid flexible means of sorting data in many different ways without use of plugboards.

This system provides a means for sorting and summarizing data which has been recorded in random sequence in the medium of punched paper tape.

DYSEAC

Second Standards Electronic Automatic Computer

MANUFACTURER

Electronic Computer Laboratory
Data Processing Systems Division
National Bureau of Standards
U. S. Department of Commerce

Photo by the National Bureau of Standards

APPLICATIONS

General purpose, simulation, real-time control.

PROGRAMMING AND NUMERICAL SYSTEM

Internal number system	Binary
Binary digits/word	45 plus check digit
Binary digits/instruction	45 plus check digit
Instructions per word	1
Instructions decoded	16
Instructions used	16
Arithmetic system	Fixed point
Instruction type	Three address
Number range	$-(4 - 2^{-42}) \leq n \leq (4 - 2^{-42})$

ARITHMETIC UNIT

	Incl Stor Access	Exclud Stor Access
Time	Microsec	Microsec
Add	192 - 1,536	48
Mult	2,304 - 3,648	2,112
Div	2,304 - 3,648	2,112
Construction	Diode gates, tube amplifiers, and electrical delay lines	
Rapid access word registers	3	
Basic pulse repetition rate	One megacycle/sec.	
	A four phase clock is used.	
Arithmetic mode	Serial	
Timing	Synchronous	
Operation	Storage and arithmetic processing are serial. Input-output external control are concurrent with arithmetic operations. In addition to the normal complement of operations, the operations of summation, accumulation, overflow check, justification, shift, and file are also included.	

STORAGE

Media	Words	Digits	Access Microsec
Mercury Delay Line	512	24,576	48-384

There is provision for up to 4,096 words of high speed storage. In addition, the computer has provisions for the attachment of many multi-channel magnetic tape or wire units, and a magnetic drum. These would operate concurrently with computation operations.

INPUT

Media	Speed
Keyboard	Manual
Paper Tape Reader	10 char/sec
Magnetic Wire	3,500 dig/sec

Keyboard and punched paper tape reader is a Flexo-writer. Alpha-numeric operation is utilized. There is provision for the attachment of a wide variety of input devices that would operate concurrently with computation. There is also a one-word addressable switch memory via a serializer unit.

OUTPUT

Media	Speed
Typewriter (Flexowriter)	10 alphanum char/sec
Paper Tape Punch	60 char/sec
CRT Display Unit	2,000 words/sec
Magnetic Wire	3,500 dig/sec

There is provision for the attachment of a wide variety of output devices that would operate concurrently with computation.

CIRCUIT ELEMENTS OF ENTIRE SYSTEM

Tubes	900
Tube types	90% are 1 type
Crystal diodes	24,500
Separate cabinets	2

There are 524 tubes in the central computer and 350 in the storage unit. The central computer utilizes 21,500 crystal diodes. The central computer has two basic types of package. One type contains tube amplifiers and diode gates. The other type contains delay lines and diode gates. There are 524 tube packages and 251 delay-line packages.

CHECKING FEATURES

Fixed
Odd - even parity check on storage.
Optional

Automatic program jump or print-outs are optional upon detection of a memory error. Also available for program checking are a wide variety of auto-monitoring operations for loading and printing out of internal storage locations and substituting new instructional addresses. Each word is checked as it is read from the memory. A real-time clock periodically initiates a storage scan which checks the entire storage.

POWER, SPACE, WEIGHT, AND SITE PREPARATION

Power, computer	12 Kw	20 KVA
Power, air cond.		35 KVA
Volume, computer		270 cu ft
Volume, air conditioner		750 cu ft
Capacity, air conditioner		18 Tons

There are two trailer vans. Van No. 1 contains the control console, input-output, computer, storage, and 12 tons of refrigeration capacity. Its internal dimensions are approximately 39 x 7 x 9 feet and weighs about 12 tons. Van No. 2 contains DC power supplies, 6 tons of refrigeration capacity, and 1,700 cubic feet of spare space. This van also has internal dimensions of 39 x 7 x 9 feet. It weighs 8 tons.

PRODUCTION RECORD

Number produced	1
Number operating	1

The DYSEAC was designed and constructed by the Electronic Computer Laboratory of the National Bureau of Standards as part of a development program under the sponsorship of the Department of Defense. It was delivered to the Signal Corps in May 1954.

RELIABILITY, OPERATING EXPERIENCE, AND TIME AVAILABILITY

Acceptance test passed in April 1954.

ADDITIONAL FEATURES AND REMARKS

For further information on this system see Transactions of the IRE-PGEC, Vol. EC-3, No. 1, Mar. 1954.
Transactions of the IRE-PGEC, Vol. EC-3, No. 2, June 1954.
Journal of the ACM, Vol. 1, No. 2, pp 57-81, April 1954.
Proceedings of the IRE, Vol. 41, Oct. 1953, pp 1380-1387.
Circular No. 551 National Bureau of Standards, January 1955.

Two counter-registers are provided for program sequencing. Each counter holds a twelve-binary-digit address. The coder may select the address in either counter as the address of the next instruction to be performed. Also, either counter-register can furnish the base number for relative addresses.

Major design emphasis was placed on versatility of control facilities and on latitude for expansion of the installation. The versatility is achieved by (1) the concurrent input-output property, (2) a self-regulation property which allows the external environment to automatically control the pace of the internal work program, (3) an interruption property which enables the machine to handle unscheduled job assignments which originate externally without advance notice and must be executed as soon as possible, and (4) the preceding three properties acting in concert enable the machine to be employed as a control element in a generalized feedback loop.

EDVAC

Electronic Discrete Variable Automatic Computer

MANUFACTURER

Moore School of Electrical Engineering
University of Pennsylvania

APPLICATIONS

Ballistic Research Laboratories

Exterior ballistics problems such as high altitude, solar and lunar trajectories, computation for the preparation of firing tables and guidance control data for Ordnance weapons, including free flight and guided missiles.

Interior ballistic problems, including projectile, propellant and launcher behavior, e.g. physical characteristics of solid propellants, equilibrium composition and thermodynamic properties of rocket propellants, computation of detonation waves for reflected shock waves, vibration of gun barrels and the flow of fluids in porous media.

Terminal ballistic problems, including nuclear, fragmentation and penetration effects in such areas as explosion kinetics, shaped charge behavior, ignition, and heat transfer.

Ballistic measurement problems, including photogrammetric, ionospheric, and damping of satellite spin calculations, reduction of satellite doppler tracking data, and computation of satellite orbital

U. S. Army Photo

elements.

Weapon systems evaluation problems, including anti-aircraft and anti-missile evaluation, war game problems, linear programming for solution of Army logistical problems, probabilities of mine detonations, and lethal area and kill probabilities of mine detonations, and lethal area and kill probability studies of missiles.

PROGRAMMING AND NUMERICAL SYSTEM

Internal number system	Binary
Binary digits per word	44
Binary digits per instruction	4 bits/command
10 bits each address	
Instructions per word	1
Instructions decoded	16
Instructions used	12
Arithmetic system	Floating and Fixed point
Instruction type	Four-address code

EDVAC Floating Point

Number range

Fixed $-(1-2^{-43}) \leq n \leq (1-2^{-43})$

Floating $-(1-2^{-33})2^{511} \leq n \leq (1-2^{-33})2^{511}$

The fractional part of floating point number has 33 bits plus sign, and the exponent of 2 may range from -512 to +511.

Instruction word format

α -Add 1 - 10	β -Add 11 - 20	γ -Add 21 - 30	δ -Add 31 - 40	Order 41 - 44
-------------------------	-------------------------	--------------------------	--------------------------	------------------

ARITHMETIC UNIT

Add time (includ. stor. access) (min 192 max 1,536)	864
Mult time (includ. stor. access) (min 2,208 max 3,552)	2,880
Div time (includ. stor. access) (min 2,256 max 3,600)	2,930

U. S. Army Photo

Construction	Vacuum-tubes and Diode-gates
Number of rapid access word registers	4
Basic pulse repetition rate	1.0 megacycle/sec
Arithmetic mode	Serial
Timing	Synchronous
Operation	Sequential

STORAGE

Media	Number of Words	Number of Digits	Access Microsec
Mercury A.D.L.	1,024	48-384	48-384
Magnetic Drum	4,608	48/Word	17,000

Includes relay hunting and closure.

The rate of information transfer to and from the drum is at one megacycle per second. The block length is optional from 1 to 384 words per transfer instruction.

Magnetic Tape	48/Word
Maximum number of units that can be connected to the system	7 Units
Maximum number of characters per linear inch of tape	112 Char/inch
Channels or tracks on the tape	8 Track/tape
Blank tape separating each record	1.5 Inches

Tape speed	75 Inches/sec
Start time	3 Milliseconds
Stop time	3 Milliseconds
Average time for experienced operator to change reel of tape	30 Seconds
Physical properties of tape	
Width	5/8 Inches
Length of reel	1250/2500 Feet
Composition	Red Oxide

The magnetic tape system has the following features:

- Variable block length from 2 to 1,024 words.
- The search order releases the machine for computation during search.
- Information which has been taken from a block and operated upon, can be automatically re-recorded in the same block.

INPUT

Media	Speed
Photoelectric Tape Reader	942 sexadec char/sec
	78 words/sec
Card Reader (IBM)	146 cards/min
	8 words/card

OUTPUT

Media	Speed
Paper Tape Perf.	6 sexadec char/sec
	30 words/min
Teletypewriter	6 sexadec char/sec
	30 words/min
Card Punch	125 cards/min
	1,000 words/min

CIRCUIT ELEMENTS OF ENTIRE SYSTEM

Type	Quantity	Type	Quantity
Tubes, total	5,937		
6Y6	1,000	6AN5	275
6J6	1,500	2D21	160
6AG7	1,127	6SN7	150
6V6	900	6AS6	50
6L6	275	Misc	500
Diodes, total	12,000		
1N297	6,000	Misc	1,200
1N 34	4,800		
Transistors, total	328		
2N398	256	2N123	4
2N1008B	60	2N167	4
2N 43	4		

CHECKING FEATURES

- Two arithmetic units perform computation simultaneously, discrepancies halt machine.
- Unused commands halt machine.
- Paper tape reader error detection.

POWER, SPACE, WEIGHT, AND SITE PREPARATION

Power, computer	52 K.W.
Space, computer	490 sq. ft. floor
Weight, computer	17,300 lbs.
Power, air cond.	25 K.W.
Space, air cond.	6 sq. ft. floor
Weight, air cond.	4,345 lbs.
Capacity, air cond.	20 Tons

PRODUCTION RECORD

Number produced	1
Number in current operation	1

COST, PRICE AND RENTAL RATES

Approximate cost, basic system	\$467,000
Rental rates for additional equipment	
I.B.M. card reader	\$82.50 per month
I.B.M. card punch	\$93.50 per month

PERSONNEL REQUIREMENTS

Typical Personnel	Three 8-Hour Shifts
Supervisors	6
Analysts	3
Programmers and Coders	14
Clerks	1
Engineers	1
Technicians	6

No engineers are assigned to the operation of the machine, but are used for development and design of additions to the machine. The technicians consult the engineers when a total break-down occurs.

RELIABILITY, OPERATING EXPERIENCE, AND TIME AVAILABILITY

Average error-free running time	Approx. 8 hours
Good time	145 hours/week
Attempted to run time	168 hours/week
Operating ratio	0.87

Figures based on last 3 years. The 23 hours per week are devoted to scheduled and unscheduled maintenance, testing, modifications and improvements, time lost due to error, etc. The 145 hours are good, useful production time. EDVAC has been operating since 1949.

ADDITIONAL FEATURES AND REMARKS

Oscilloscope and neon indicator for viewing contents of any storage locations at any time.

Exceed capacity options: halt, ignore, transfer control, or go to selected location.

Unused instruction (command) halt.

Storage of previously executed instruction and which storage location it came from, for viewing during code checking.

Storage of current instruction and storage location it originated from.

Address halt when prescribed address appears in any of 4 addresses of instruction to be executed by computer.

Tape reader error detection.

Built in automatic floating point equipment.

Magnetic tape auxiliary storage unit and high speed printing techniques are being investigated.

Punching one card requires from 384 to 768 microseconds. The computer may proceed between cards.

INSTALLATIONS

Ballistic Research Laboratories
Aberdeen Proving Ground, Maryland

FUTURE PLANS

A second magnetic drum system, of 16,128 words capacity is being added to the EDVAC. The transistorized track selector will permit channel switching in 48 microseconds.

ELECOM 50

Electronic Computer Type 50

MANUFACTURER

Underwood Corporation
Electronic Computer Division

Photo by Underwood Corporation, Electronic Computer Division

APPLICATIONS

Commercial (Out of Production)

PROGRAMMING AND NUMERICAL SYSTEM

Internal number system	Decimal
Decimal digits per word	10 plus sign
Instructions decoded	42 plus combinations
Arithmetic system	Fixed point
Number range	.000001 to 99999999

ARITHMETIC UNIT

	Exclud Stor Access
	Microsec
Add time	650
Mult time	39,000
Construction	Vacuum tubes
Rapid access word registers	3
Basic pulse repetition rate	67 Kc/sec
Arithmetic mode	Serial
Timing	Synchronous
Operation	Sequential

One minor cycle is 650 microseconds. Multiplication requires 60 minor cycles.

STORAGE

Media	Words	Digits	Access Microsec
Magnetic Drum (Main)	100	1,000	33,000
Magnetic Drum (Working Registers)	3	30	325

INPUT

Media	Speed
Keyboard	Manual
Paper Tape	20 dec dig/sec

OUTPUT

Media	Speed
Printers (Two-gang)	10 char/sec
Paper Tape	2 dec dig/sec

The printers operate in parallel.

CIRCUIT ELEMENTS OF ENTIRE SYSTEM

Tubes	160
Tube types	5
Crystal diodes	2,000
Number of different kinds of plug-in units	42
Number of separate cabinets, excluding power supplies and air conditioners	3

POWER, SPACE, WEIGHT, AND SITE PREPARATION

Power, computer	2 Kw
Volume, computer	50 cu ft
Area, computer	20 sq ft
Weight, computer	750 lbs

PRODUCTION RECORD

System is out of production. As of June 1957, the following figures were reported:

Produced	3
In production	50
Operating	3
On order	50

COST, PRICE AND RENTAL RATES

Approximate cost of basic system	\$22,500
Rental rates of basic system (As of June 1957)	\$ 600/month

PERSONNEL REQUIREMENTS

Manufacturer	
Daily Operation	Tech and Operators
One 8-hour shift	1
Two 8-hour shifts	2
Three 8-hour shifts	3

RELIABILITY, OPERATING EXPERIENCE, AND TIME AVAILABILITY

Manufacturer	
Average error-free running period	6 Hours

ADDITIONAL FEATURES AND REMARKS

Manufacturer
Simple operation
Programming by manufacturer
2,400 step program tape
Interchangeable program tapes

INSTALLATIONS

(As of June 1957)
Underwood Corporation
Electronic Computer Division
35-10 36th Avenue
Long Island City 6, New York (1)

Underwood Corporation
One Park Avenue
New York, New York (2)

American Telephone and Telegraph Company
195 Broadway
New York 7, New York

ELECOM 100

Electronic Computer Model 100

MANUFACTURER

Underwood Corporation
Electronic Computer Division

APPLICATIONS

Manufacturer

Engineering and scientific. System not in production.
U.S. Army Aberdeen Proving Ground
Missiles, aircraft systems accuracy, expansion of firing tables, fire control problems.
Reeves Instrument Company
The computer is owned by the U.S. Navy, Bureau of Aeronautics, and is operated by Reeves Instrument Company under Project Cyclone.

PROGRAMMING AND NUMERICAL SYSTEM

Internal number system	Binary
Binary digits per word	30
Binary digits/instruction	30
Instructions per word	1
Instructions decoded	8
Instructions used	8
Arithmetic system	Fixed point
Instruction type	Three address
Number range	$-(4 \cdot 2^{-27})$ to $(4 \cdot 2^{-27})$

The 8 instructions include an "external operation" which, in turn, includes six different operations. Octal number system is used.

Photo by Underwood Corporation, Electronic Computer Division

ARITHMETIC UNIT

Construction	Vacuum tubes
Basic pulse repetition rate	100 Kc/sec
Arithmetic mode	Serial
Timing	Synchronous (Magnetic Drum) Asynchronous (Magnetic Tape)
Operation	Sequential
25-50 operations per second may be performed, including drum storage access.	

STORAGE

Media	Words	Access Microsec
Magnetic Drum	512	20,000
Magnetic Tape	60,000	

Access time is the maximum value. One block of tape is equivalent to one channel on the drum (64 words). A transfer, or movement of one block takes approximately 2 seconds.

INPUT OUTPUT

Media	Speed
Typewriter (Flexowriter)	Manual
Paper Tape (Flexowriter)	7.5 octal dig/sec
Typewriter	7.5 char dig/sec

CIRCUIT ELEMENTS OF ENTIRE SYSTEM

Tubes	230
Tube types	6
Crystal diodes	2,200
Separate cabinets	2
Number of different kinds of plug-in units	5

CHECKING FEATURES

Overflow indication and halt
Out of synchronous for tape and halt
Engineering diagnostic tests

POWER, SPACE, WEIGHT, AND SITE PREPARATION

Power, computer	3.5 Kw
Area, computer	120 sq ft

PRODUCTION RECORD

(June 1957 figures)

Number produced	3
Number operating	3

System out of production

COST, PRICE AND RENTAL RATES

(June 1957 figures)

Approximate cost of basic system \$60,000.
System is no longer in production.

Photo by U. S. Army Development and Proof Services

PERSONNEL REQUIREMENTS

One engineer and one technician required per 8 hour shift.

RELIABILITY, OPERATING EXPERIENCE, AND TIME AVAILABILITY

First unit passed acceptance test on 9 December 1952.

U. S. Army, Aberdeen Proving Ground, D & FS	
Good time	1,471 Hours
Attempted to run time	2,225 Hours
Operating ratio (Good/Attempted to run time)	0.66

FUTURE PLANS

System is no longer being manufactured.

INSTALLATIONS

Development and Proof Services
Aberdeen Proving Ground, Maryland

Reeves Instrument Corporation
215 E. 91st Street
New York 28, New York

ELECOM 120

Electronic Computer Model 120

MANUFACTURER

Underwood Corporation
Electronic Computer Division

Photo by Underwood Corporation, Electronic Computer Division

APPLICATIONS

Manufacturer

Engineering and scientific applications. (Out of production).

Westinghouse Electric Corporation

Located at the Kansas City, Missouri, Engineering Department, the system is used for all types scientific computing, e.g. mechanical design, and stress calculations, and for semi-automatic data reduction.

Shell Development Company

Located at 3737 Bellaire Blvd., Houston, Texas, the system is used for scientific calculations arising in research and for data processing.

RADC Griffiss Air Force Base

Located in Bldg. 102, RADC, Griffiss AFB, N. Y., the system is used for scientific and engineering applications.

PROGRAMMING AND NUMERICAL SYSTEM

Internal number system	Decimal
Decimal digits/word	8 plus sign
Decimal digits/instruction	10
Instructions per word	1
Instructions decoded	33
Instructions used	33

Arithmetic system	Fixed and floating point
Instruction type	Two address
Number range	
Fixed point	$-(10 \cdot 10^{-10}) \leq n \leq (1 \cdot 10^{-10})$
Floating point Exponent	$-50 \leq c \leq 49$
Coefficient	$-(1 \cdot 10^{-8}) \leq c \leq (1 \cdot 10^{-8})$
Floating point operation is optional and is supplied with fixed point at extra cost.	

ARITHMETIC UNIT

Manufacturer

	Exclud Stor Access
	Microsec
Add time	330
Mult time	18,300
Div time	18,700
Construction	Vacuum tubes and crystal diodes
Rapid access word registers	3
Basic pulse repetition rate	105 Kc/sec
Arithmetic mode	Serial
Timing	Synchronous
Operation	Sequential
Above operation times are for average 10 digit multiplier, dividend and divisor, respectively.	

Photo by Griffiss Air Force Base, RADC

STORAGE

Manufacturer	Media	Words	Digits	Access Microsec
	Magnetic Drum	1,000-10,000		8,300 avg.
	Magnetic Drum	10-100		1,670 avg.
Main storage is on single head per channel basis. Fast access storage is a group of recirculating channels.				
Griffiss AFB				
	Magnetic Drum	1,000	8 plus sign	20,000 max. 330 min.
	Magnetic Tape (2) (Potter Mod 902) Shell	125,000	8 plus sign	1,600
	Magnetic Drum	1,000	8 plus sign	20,000 max
	Magnetic Tape Westinghouse	100,000	8 plus sign	10 ⁶ /50 words
	Drum	1,010	8	330

INPUT

Manufacturer	Media	Speed
	Typewriter	Manual and 8 char/sec
	Paper Tape reader	8 to 400 char/sec
	Magnetic Tape	400 char/sec
The typewriter is standard equipment. The high-speed paper tape reader is optional. One magnetic tape unit is supplied as standard equipment. Standard model includes controls for additional tape units.		
Griffiss AFB		
	Paper Tape (Flexowriter)	8 char/sec
	Paper Tape (Ferranti)	200 char/sec
	Keyboard (Flexowriter)	Manual
Shell		
	Paper Tape (Flexowriter)	1 word/sec
	Paper Tape (Ferranti)	20 words/sec
	Keyboard (Flexowriter)	Manual
For program check-out and manual modification of program on data. Paper tape reading system does not operate satisfactorily. There is no error detection in reading.		
Westinghouse		
	Paper Tape	200 char/sec
	Paper Tape (Flexowriter)	8 char/sec

Photo by Griffiss Air Force Base, RADC

OUTPUT

Manufacturer	Media	Speed
	Typewriter	8 char/sec
	Paper Tape	8 or 60 char/sec
	Magnetic Tape	400 char/sec
Typewriter is standard equipment. High speed paper tape punch is optional.		
Griffiss AFB	Typewriter (Flexowriter)	8 char/sec
Shell	Typewriter (Flexowriter)	1 word/sec
	Paper Tape (Flexowriter)	1 word/sec
	Paper Tape (Yawman)	6 words/sec
Westinghouse	Paper Tape	60 char/sec
	Paper Tape (Flexowriter)	8 char/sec
	Typewriter (Flexowriter)	8 char/sec

CIRCUIT ELEMENTS OF ENTIRE SYSTEM

Tubes 400
Crystal diodes 4,500
95% of tubes are of two basic types. This system utilizes the 12AT7, 6CL6, 5687, and 2C51 in the arithmetic unit. Diodes used are 1N34A, 1N140 and 1N91.

CHECKING FEATURES

Internal check for forbidden pulse combinations and check of drum-writing operations. Parity check on tapes with automatic re-read.

POWER, SPACE, WEIGHT, AND SITE PREPARATION

Manufacturer	Power, computer	Volume, computer	Weight, computer
	5 to 7 Kw	200 cu ft	3,500 lbs
These figures are for computer complete with control desk and one tape unit.			
Griffiss AFB	Power, computer 7 Kw	7.5 KVA	0.9 pf
	Volume, computer	200 cu ft	
	Area, computer	50 sq ft	
	Room size	400 sq ft	
	Weight, computer	4,500 lbs	
Computer sets on locally fabricated false floor.			
Air conditioner is shared with many other equipments.			

Shell

Power, computer	7 Kw	7.5 KVA	0.9 pf
Volume, computer		200 cu ft	
Area, computer		93 sq ft	
Room size		10 ft x 20 ft	
Floor loading		35 lbs/sq ft	
Weight, computer		3,500 lbs	

Sound-proof material on walls. Exhaust system.
Two tons additional air-conditioning in air-conditioned room.

Westinghouse

Power, computer	5 Kw	5 KVA	
Power, air cond		4.4 KVA	0.8 pf
Volume, computer		250 cu ft	
Volume, air conditioner		42 cu ft	
Area, computer		95 sq ft	
Area, air conditioner		6.5 sq ft	
Room size, computer		20 ft x 20 ft	
Room size, air conditioner		5 ft x 4 ft min	
Floor loading		40 lbs/sq ft	
		800 lbs concen max	
Capacity, air conditioner		5 Tons	
Weight, computer		4,000 lbs	
Weight, air conditioner		940 lbs	

Power distribution transformer. 5 ton air conditioner.

Photo by Republic Aviation Corporation

PRODUCTION RECORD

(June 1957)

Number produced	5
Number in operation	5

System is no longer in production.

COST, PRICE AND RENTAL RATES

Manufacturer
(June 1957)

Approximate cost of basic system \$97,000. Rental rates of basic system \$3,500/month for complete system, including maintenance.
System is out of production.

Griffiss AFB
System purchased at \$90,000 plus \$35,000 for additional equipment.

Shell
Purchased at \$90,000, for central processor, control desk, Ferranti reader, Yawman punch, and Potter tape device.

Westinghouse
Basic system purchased at \$90,000.
Additional equipment

High Speed Punch	\$ 3,600
Photo Electric Reader	5,000
(2) Flexowriters	5,200
Test Equipment	2,000

Photo by Shell Development Company, Exploration and Production Research Division

Card to tape converter rents at \$85.
Maintenance performed by local computer group.

PERSONNEL REQUIREMENTS

	One 8-Hour Shift	Two 8-Hour Shifts	Three 8-Hour Shifts
Engineers	1	2	3
Tech and Operators	1	2	3

Griffiss AFB

	One 8-Hour Shift	
	Used	Recommended
Engineers	1	1

Operation tends toward closed shop.
Methods of training used include instruction manuals and on-the-job training.
Shell

Five persons are utilized with the system, covering two 8-hour shifts and performing the functions of supervision, analysis, programming, coding, operating, and engineering.

Westinghouse

	One 8-Hour Shift	
	Used	Recommended
Supervisors	1	1
Analysts	0	1
Programmers	3	3
Coders	3	4
Clerks	0	2
Operators	1	1
Engineers	1	1

Operation tends toward open shop.
Methods of training include on-the-job training, formal classes, assign new personnel to work with experienced. All system information for Elecom 120 only. Magnetic tape use has been discontinued.

RELIABILITY, OPERATING EXPERIENCE, AND TIME AVAILABILITY

Operating ratio (Good/Attempted to run) 0.90 to 0.95
Figure based on eight month period.

Above up-times (machine time available for problem work divided by total time) reported for 5 Elecom 120 Computer installations. At one location, up-times of 100% and 99.9% were obtained for two successive months.

Photo by Westinghouse Electric Corporation, Aviation Gas Turbine Division

Shell

Average error-free running period 5 Hours
Good time 80 Hours/Week (Average)
Attempted to run time 100 Hours/Week (Average)
Operating ratio (Good/Attempted to run time) 0.80
Above figures based on period from Jun 59 to May 60
Passed Customer Acceptance Test Jun 54
Time is not available for rent to outside organizations.

Westinghouse

Good time 60 Hours/Week (Average)
Attempted to run time 62 Hours/Week (Average)
Operating ratio (Good/Attempted to run time) 0.97
Above figures based on period from May 54 to Apr 60
Passed Customer Acceptance Test May 54
Time is not available for rent to outside organizations.

Above time is average for a 6 year period. Drastic changes in scheduled work load have occurred during this time.

ADDITIONAL FEATURES AND REMARKS

Westinghouse

An outstanding feature is the high speed input-output, compared to internal speed mixture of numeric and alphabetic information. System is very good with automatic data taking and plotting equipment.

Little is given to magnetic tape protection except air conditioning for temperature.

Little preventive maintenance done. Circuit modifications have been made that increase reliability. 6677 tubes to replace 6CL6 have improved system.

FUTURE PLANS

Shell

Retirement is planned during last quarter of 1960.

INSTALLATIONS

Rome Air Development Center
Griffiss Air Force Base, New York

Shell Development Company
3737 Bellaire Blvd.
Houston, Texas

Westinghouse Electric Company, Box 288
Kansas City, Missouri

ELECOM 125 125 FP

Elecom Type 125 Computer and Elecom Type 125 File Processor

MANUFACTURER

Underwood Corporation
Electronic Computer Division

Photo by Underwood Corporation, Electronic Computer Division

APPLICATIONS

Manufacturer

Commercial, engineering and scientific. The Elecom 125FP is primarily commercial. The system is no longer in production.

Sandia Corporation

Located in Building 880 at the Sandia Corporation, Albuquerque, New Mexico, the Elecom 125 is used for scientific computation and engineering studies.

PROGRAMMING AND NUMERICAL SYSTEM

Internal number system	Decimal
Decimal digits/word	10 and sign
Decimal digits/instruction	10
Instructions/word	1
Instructions decoded	36
Instructions used	36
Arithmetic system	Floating and fixed
Instruction type	Two address
Number range	
Coefficient range	$-(1-10^{-8}) \leq c \leq (1-10^{-8})$
Exponent range	$-50 \leq e \leq 49$
Fixed point range	$-(1-10^{-10}) \leq n \leq (1-10^{-10})$

Floating point is optional at extra cost and is additional to fixed point. Fixed point is standard. The Elecom 125FP utilizes 2 decimal dig/alpha char. It operates on "Items" containing any integral number of words. Fixed program, switch-selected; sequence, collate, select, collate and select, separate, and substitute. The following combinational operations are available as an option: Select-separate,

collate-separate, substitute-separate, collate-select-separate.

ARITHMETIC UNIT

	Incl Stor Access	Exclud Stor Access
	Microsec	Microsec
Add time	3,500	330
Mult time	22,000	18,000
Div time	22,000	18,000
Construction		Vacuum tubes
Rapid access word registers	3	
Basic pulse repetition rate	132 Kc/sec	
Arithmetic mode	Serial	
Timing	Synchronous	
Operation	Sequential	
Above operation time is based on average 10 decimal digit multiplier, dividend and divisor.		
Sandia Corporation		
	Incl Stor Access	Exclud Stor Access
	Microsec	Microsec
Add time	3,500	330
Mult time	22,000	18,000
Div time	22,000	18,000

The above figures are obtained for 10 digit numbers.

STORAGE

Media	Words	Access Microsec
Magnetic Drum	4,000 to 10,000	8,300 avg.
Magnetic Drum	50 to 100	1,670 avg.

Main storage operates on a single head per channel basis. The rapid-access storage is a recirculation channel. The Elecom 125 FP has a 100 word acoustic delay line.

Sandia Corp.

Media	Words	Digits
Magnetic Drum	4,000	10 plus sign
Paper Tape		
Magnetic Tape		

INPUT

Media	Speed
Typewriter	8 char/sec and Manual
Paper Tape	8 to 400 char/sec
Magnetic Tape	6,000 char/sec
Cards (IBM 528 or similar)	

The typewriter is standard equipment. The high speed tape reader and punched card unit is optional. Magnetic tape synchronizing circuits and controls are included as standard equipment. The Elecom 125 FP unit is utilized in conjunction with magnetic tape and typewriter. The typewriter and punched paper tape are used for checking and control.

Sandia Corp.

Paper Tape	400 char/sec
Magnetic Tape	7,500 char/sec
Manual	

OUTPUT

Media	Speed
Typewriter	8 char/sec
Paper Tape	8 or 60 char/sec
Magnetic Tape	6,000 char/sec
Cards (IBM 523)	6,000 char/sec
Tabulation (IBM 407)	

Typewriter is standard equipment. High speed paper tape and card equipment are optional.

Sandia Corp.

Typewriter (Flexowriter)	8 char/sec
Paper Tape	60 char/sec
Magnetic Tape	7,500 char/sec

CIRCUIT ELEMENTS OF ENTIRE SYSTEM

Manufacturer

Tubes	450 for Elecom 125; 250 for 125 FP
Diodes	2,500 for Elecom 125 FP

95% of the tubes are of 2 types. Tube types used are the 6CL6, 12AT7, 5687, and the 5670.

CHECKING FEATURES

Manufacturer

Internal check for forbidden pulse combinations
 Check of drum writing circuits
 Parity check on tape with automatic re-read.
 The Elecom 125 FP makes a parity check on all data.

Sandia Corp.

Magnetic tape circuits contain check to determine if block read contains same number of digits as block contained when written. Automatic re-read takes place if error is detected. The storage signals are continuously monitored for forbidden combinations.

POWER, SPACE, WEIGHT, AND SITE PREPARATION

Power, computer	5-7 Kw
Volume, computer	400 cu ft
Weight, computer	4,000 lbs
Capacity, air conditioner	5 Tons

Volume and weight figures are for computer (complete) with control desk and three tape units. Room air conditioning is recommended. No built-in air conditioning is supplied with system.

Elecom 125 FP requires 7 Kw and occupies 200 cu ft, including control desk and 5 magnetic tape units. Five tons of room air conditioning is recommended. No built-in air conditioning is supplied with system.

Sandia Corp.

Power, computer	20 KVA
Power, air conditioner	2 KVA
Volume, computer	250 cu ft
Area, computer	50 sq ft
Weight, computer	8,000 lbs

Site preparation includes platforms over connecting cables, duct work over units to draw air through units for cooling, and normal dust prevention.

PRODUCTION RECORD

Manufacturer

(June 1957 figures)

Number produced	6
In production	2
Number in operation	6
On Order	3

System is no longer in production.

COST, PRICE AND RENTAL RATES

Manufacturer

(June 1957 figures)

	Price
Computer only	\$155,000
Computer System with File Processor	350,000 to 450,000
File Processor only	85,000
	Monthly Rental
Computer only	\$4,185
Computer System with File Processor	8,500 to 9,500
File Processor only	2,295

Sandia Corp.

Console, main frame, power supply, storage, tape drive (4 ea.), paper tape punch, Ferranti, paper tape reader, and Flexowriter cost \$122,500.

Three Flexowriters are used at a total cost of \$7,578.

PERSONNEL REQUIREMENTS

	One 8-Hour Shift	Two 8-Hour Shifts	Three 8-Hour Shifts
Engineers	1	2	3
Tech & Operators	1	2	3

Above figures are the same for the File Processor.
 Sandia Corp.

One operator, trained on the job, is required. Present use is primarily for engineering studies with job requestor operating facility himself.

RELIABILITY, OPERATING EXPERIENCE, AND TIME AVAILABILITY

Manufacturer

Operating ratio (Good/Attempted to run) 0.90 to 0.95
Figures based on an eight-month period.

Above up-times (machine time available for problem work divided by total time) reported for 5 Elecom 120 computer installations. (Much of the Elecom 125 internal circuitry is substantially the same as that of Elecom 120). At one location, up times of 100% and 99.9% were obtained for two successive months.

Sandia Corp.

System is used very little at present time.

ADDITIONAL FEATURES AND REMARKS

Manufacturer

Two (2) four-digit base registers (B-boxes) are included as standard equipment.

An important partner in the Elecom 125 System is the Elecom File Processor. This is an entirely separate piece of equipment, designed and engineered to handle the sequencing, collating, extracting and similar operations necessary in day-to-day business applications.

The Elecom File Processor extracts from the voluminous "Library Tapes", the particular items upon which processing is to be done. It is the job of the Elecom File Processor to pick the pertinent items out of the tape file, so that the associated Computer wastes no time in "searching" through unwanted items. Once the items have been processed by the Elecom 125 Computer the Elecom File Processor puts them back into their proper place (in sequence) in the main file.

The picture shows the Elecom File Processor on the left, the Elecom 125 Computer on the right. The Magnetic Tape Units and the Magnetic Tape Interconnecting panel are in the rear. The Elecom High-Speed Line Printer is not shown.

FUTURE PLANS

Manufacturer

Elecom Universal Data Converter - A device for transcribing data between Elecom magnetic tapes and those of other manufacturers. In addition, the converter will be able to handle punched paper tape and punched cards. The converter is designed to make the Elecom 125 System, or the Elecom 125 Computer compatible with the input/output from it to any other data processing equipment currently manufactured.

INSTALLATIONS

(As of June 1957)

Sandia Corporation (2)
Albuquerque, New Mexico

Underwood Corporation (1)
Data Processing Center
New York City, New York

The Texas Company
Houston, Texas

Sylvania Electric Corporation (1)
Waltham, Massachusetts

FADAC

Field Artillery Digital Automatic Computer

MANUFACTURER

Autonetics Division
North American Aviation, Incorporated

APPLICATIONS

FADAC -Field Artillery Digital Automatic Computer is a rugged, general purpose, portable computer developed under the sponsorship of Frankford Arsenal. FADAC design is based on the existing requirements for solving gunnery problems of tube artillery, free rockets, and missiles. Extreme versatility also enables solution of field artillery support computations related to surveying, counter battery, fire planning, flash and sound ranging, reduction of meteorological data, and master control and programming for automatic checkout of missile systems.

Mechanization of FADAC is based on solution of the differential equations of projectile motion from firing to impact. Necessary input data such as target location, powder temperature, gun location, meteorological data (inserted manually or by tape reader) are entered by means of a simplified keyboard. FADAC training time for experienced fire control personnel is extremely short. When all data are entered, de-

Photo by U. S. Army

pression of a button initiates computation; gun orders comprising deflection, quadrant elevation, fuze time, and charge are displayed in decimal form.

A high-speed automatic logic tester and a component tester are also available with FADAC; these are in addition to the self-checking features within the computer.

PROGRAMMING AND NUMERICAL SYSTEM

Internal number system	Binary
Binary digits/word	35
Binary digits/instruction	35
Instructions/word	1
Arithmetic system	Fixed point
Instruction type	1 plus 1
Address of operand and next instruction	

Control Panel of the FADAC Computer

Photo by U. S. Army

The matrix switches (A) allow the operator to enter fire control parameters or select prestored parameters. Depression of one button in the vertical row and one button in the horizontal row selects one of sixty-four locations and identifies one particular problem parameter. The manual keyboard (B) allows the operator to enter problem information for different type fire missions which has not been prestored in the memory. The mechanical tape reader (C) is used for entering the meteorological data which are contained on a punched tape. Final problem solutions are displayed on the 16 Nixie tubes (D).

Word format

1	1	2	31
Parity	Sign	Spacer	Numerical Absolute Value

Five 1-word registers for arithmetic and control
One 2-word register for output information storage
System is straight binary for internal operations with automatic conversions to other codes for input-output. Twos complement notation for negative numbers is used.

ARITHMETIC UNIT

Add time 7.8 Microseconds
Execution time for each instruction is 7.8 microseconds. High speed (2-bits at a time) multiplication, division and shifts.
Arithmetic mode Parallel by function
Serial by bit

Timing Synchronous
Pulse repetition rate 448,000 pulses/sec
Operation Sequential

STORAGE

Media Words
Magnetic Disc (Main) 4,096
Magnetic Disc (Hi-Speed) 32
32 channels of 128 words each, of which 24 channels are designated as permanent storage and 8 channels as working storage.
The 32 words are two word high speed loops. Disc rotates at 6,000 rev/min and its storage is non-volatile.

INPUT

Media	Speed
Keyboard	Manual
Paper Tape	Mechanical
Paper Tape	700 char/sec
Gunnery Off Console	Manual
Another FADAC	
Magnetic Tape	
Other FIELData Equipment	
Teletype	

Five or eight channel paper tape, 5-level teletype or FIELData code. Automatic conversion to machine language provided. Maximum input rate is 4,250 char/sec.

OUTPUT

Media
Visual Display (Nixie)
Signal Level (Console)
Another FADAC
Battery Display
Printer
Magnetic Tape
FIELData Equipment
Teletype Equipment

System provides information in either 5-level teletype, 2-wire teletype, or FIELData codes. Maximum output rate is approximately 4,250 characters per second.

CIRCUIT ELEMENTS OF ENTIRE SYSTEM

Transistorized

CHECKING FEATURES

Parity check on FIELData information transfer.
Verify feature on input in program-full mode.
Marginal test provision for preventive maintenance.
Voltage transient and temperature warning indicators.

POWER, SPACE, WEIGHT, AND SITE PREPARATION

Power, computer 0.700 Kw
Three phase, 4-wire, 400 cycles/sec, 120/208 volts.
Automatic power loss interlocks and phase reversing features are provided.

Volume, computer 5 cu ft
Weight, computer 175 lbs

System operates from -25°F to 125°F (external ambient at sea level). Capable of operating to -40°F with kit. Automatic temperature protection is provided.

ADDITIONAL FEATURES AND REMARKS

Additional features include logic provision for expandable memory; standardized etched boards utilized for reduction of logistics problems; ruggedized for field use; system design provides auxiliary equipment on an integrated basis for computer memory loading, automatic computer testing, and subassembly maintenance, and peripheral equipment for additional operator control in program checkout.

FOSDIC

Film Optical Sensing Device for Input to Computers

MANUFACTURER

U. S. Department of Commerce
National Bureau of Standards

APPLICATIONS

System is utilized for the reading and conversion of microfilm copies of Decennial Census Schedules (position marked documents) to magnetic tape for computer input.

PROGRAMMING AND NUMERICAL SYSTEM

Internal number system	Binary coded decimal
Number bin cod dec dig/word	Variable
Number instructions decoded	45
Arithmetic system	None
Instruction type	Plugboard

FOSDIC converts coded marks on microfilmed documents to information on magnetic tape in the following manner: (1) A flying spot scanner tube is programmed to make several calibration tests on each document measuring dark level, light level, tilt, horizontal and vertical reduction ratios. (2) The beam is then programmed using major and minor jump

Photo by the Bureau of the Census

instructions (coordinate increases or decreases) to locate 1/4" black reference marks called "indexes". (3) From a given index, program steps then positions the beam over each possible marking position, measuring light output and interpreting the result as either an "answer" or "no answer". (4) The most dominant (darkest) of the answers is held in memory until all positions for a given question have been scanned. This answer (as coded by the program plug-board) is written on magnetic tape. (5) Magnetic tape format is UNIVAC compatible, 100 pulses/inch, 720 character blocks in fixed format. The FOSDIC internal word and frame lengths are variable, however, and many formats (number of frames per block, number of digits per word) are possible under program control.

STORAGE

Temporary fast storage by means of flip-flops.

INPUT

Medium	Speed
Microfilm	2 - 4 frames/sec
Flying spot tube scanning	

OUTPUT

Medium	Speed
Magnetic tape	2,376 char/sec
Speed depends on amount of document information	

CIRCUIT ELEMENTS OF ENTIRE SYSTEM

Type	Quantity
Tubes	1,200
Diodes	2,000
Transistors	3,000

FOSDIC consists of a Scan Unit constructed of vacuum tubes, cathode ray tubes, photocells, magnetron beam-switching tubes, and conventional point-to-point wiring; and a Program Control Unit constructed of solid-state components, transistors, diodes, etc., mounted on printed circuit boards.

Photo by the Bureau of the Census

CHECKING FEATURES

Numerous scan, magnetic tape and program interlocks, sprocket and parity checking on magnetic tape output are utilized.

POWER, SPACE, WEIGHT, AND SITE PREPARATION

Power, computer	5 Kw	5 KVA	1.0 pf
Volume, computer		3,000 cu ft	
Area, computer		300 sq ft	
Room size, computer		20 x 20 x 10 ft	
Floor loading, computer		140 lbs/sq ft	

Figures are for each system. Air conditioner is part of integrated system.

Site preparation included alteration of area from previously subdivided sections onto single enclosed area; provision of air ducts and space air conditioning equipment; alteration of lighting fixtures; provision of power conduits and outlets; fire wall construction.

PRODUCTION RECORD

Number produced to date	5
Number in current operation	4
Number in current production	4

FOSDICS currently manufactured by Bureau of the Census personnel for their own production needs.

COST, PRICE AND RENTAL RATES

Total cost for development and construction of 5 FOSDIC systems with 1 magnetic tape unit each
\$633,000

PERSONNEL REQUIREMENTS

	Three 8-Hour Shifts
Supervisors	3
Analysts	
Programmers }	3
Coders	
Engineers	2
Technicians	10
In-Output Oper	12

Operation tends toward open shop.

Methods of training used

Training branch conducts formal classroom sessions for programmers, operators (followed by on-the-job training) executive orientation, brush-up seminars. Classroom and on-the-job training also conducted for engineers and technicians.

Programmers are customer employees.

RELIABILITY, OPERATING EXPERIENCE, AND TIME AVAILABILITY

Date this system passed Acceptance Test Sep 59-Mar 60
Time is not available for rent to outside organizations.

Each system is operated an average of about 100 hours per week, excluding scheduled maintenance.

ADDITIONAL FEATURES AND REMARKS

Prior to the invention of FOSDIC the bulk input medium has generally been punch cards but a few figures showing our experience in 1950 points out certain of their limitations. At that time we used a force of nearly 2000 key punch operators at the peak of operations, and over 14 months was needed at a cost of almost six million dollars just to record the enumerated population and housing data on cards.

These facts led Census back to the Bureau of Standards for additional study and review of the input problem. Out of this interchange grew FOSDIC I. The name is an abbreviation of Film Optical Sensing Device for Input to Computers. Designed and built for Census by the Bureau of Standards, it promised a breakthrough in the input problem area.

The principle was based on field documents being position coded (by checking the proper box), micro-filming the documents, and scanning the microfilm with an electronic beam. The detected position codes are written on the magnetic tape which is our computer input medium.

This early model FOSDIC served Census well. Several special tasks were successfully processed through its use. Its chief contribution, however, was in showing the way to a more versatile, faster, less restrictive system. Subsequently, Bureau of Standards and Census engineers collaborated on a successor, FOSDIC III. In the meantime, the Bureau of Standards had produced FOSDIC II which is used by the Weather Bureau to do a high-speed search on large punch card files which have been reduced to microfilm.

FOSDIC III captured our imagination. It features a completely programmable scan, permits tremendous flexibility in schedule and questionnaire design, and has such features as automatic calibration on each microfilm frame measuring dark level, light level; compensation for tilt or non-parallelism due to photography or printing; compensation for size variation in the filming reduction process; blank line elimination (conditional jumps over partially-filled out documents); and dominant mark, an ability to choose the darkest of several competing marks, thus eliminating the problem of erasures. It is plugboard programmed and has about 45 instructions and program loops. Iterations are possible as with internally-stored program computers. Documents are limited only to be 20" x 14" or less, and their microfilm counterparts will be translated to programmer-chosen codes on magnetic tape at about 100 frames or documents per minute. This works out to an average character rate of about 19,000 - 24,000 characters per minute. A tough rate for a key punch operator to match.

The 1960 Decennial Census

The equipment utilized 5 FOSDIC systems consists of:

4 Univac Scientific 1105 Computers with 18 tape units each, 2 Univac I Computers with 10 tape units each, 2 600 lines per minute High-Speed Printers, equipped with Block Buffers, 1 Card-to-Magnetic Tape Converter, and a host of miscellaneous auxiliary equipment of a minor nature.

Adopted procedures for magnetic tape handling include fire wall construction; metallic containers for magnetic tape, fire fighting organization and training, control system for defective and damaged tapes, and standardization of tape reel lengths and markings.

INSTALLATIONS

Bureau of the Census
Washington, D. C.

GE 100 ERMA

General Electric 100 Electronic Recording Method
Accounting

MANUFACTURER

General Electric Company
Computer Department
Phoenix, Arizona

APPLICATIONS

Located in San Francisco, Berkeley, San Jose, Los Angeles, North Hollywood, Covina, and Paramount, California, the systems are being used for commercial deposit accounting (checking accounts). The Bank of America is now operating 7 ERMA Centers in the locations indicated above. Each center is equipped with 2 to 3 GE-100 Computing Systems depending on projected account volume for area being serviced. Checks and deposits, which are delivered to the ERMA Centers in the early evening, are processed and sorted at night for early morning return to the branches.

Photo by Bank of America (Abbate Photo)

STORAGE

	No. of Words	No. of Digits	Access Microsec
Medium			
Magnetic Core	4,000	28,000	32

Work structure consists of 7 decimal characters.
The first character contains sign, numeric-alpha
numeric designation and checking digits.

INPUT

Media	Speed
Magnetic Tape	30,000 char/sec
3/4 inch tape - 10 channel - 2 digit in parallel.	
Paper Tape	200 char/sec
7 channel punch paper tape photo reader	
Flexowriter	10 char/sec
7 channel punch paper tape mechanical reader	
Sorter/readers	750 items/min
Magnetic ink coded documents. The sorter/readers are equipped with character recognition.	

OUTPUT

Media	Speed
Magnetic Tape	30,000 char/sec
Flexowriter	10 char/sec
Printer	600-900 lines/min
Revolving drum/hammer type, operable both off-line and on-line. The printer is used off-line with magnetic tape input.	

POWER, SPACE, WEIGHT, AND SITE PREPARATION

Power, computer	150 Kw
Power, air conditioner	185 Kw
Volume, computer	18,000 cu ft
Volume, air conditioner	33,500 cu ft
Area, computer	2,000 sq ft
Area, air conditioner	1,900 sq ft
Room size, computer	80 ft x 25 ft x 9 ft
Room size, air conditioner	87 ft x 20 ft x Mezzanine
Floor loading	250 lbs/sq ft
Capacity, air conditioner	150 Tons
Weight, computer	23,000 lbs

False ceilings and plenums are required for air supply and negative pressure. Building type is either of pre-stressed concrete panels or cast concrete: no modifications are necessary since the buildings are specifically designed as ERMA Centers. Power distribution is provided by underfloor conduit and pull boxes.

PERSONNEL REQUIREMENTS

Because of the recent development and installation of our current GE 100 Systems, accurate figures are not yet available on our ultimate personnel requirements. However, typical operating personnel in an ERMA Center consist of a manager, assistant managers, branch liaison officers, console operators, sorter/reader operators and printer operators. Programming activities for all our various installations are centralized within the Bank of America's Systems and Equipment Research Department. Engineer and technician requirements are to be determined by the manufacturer, General Electric Company, under terms of the contractual agreement to provide necessary maintenance.

Operation tends toward open shop.

Key personnel, i.e. managers, liaison officers and console operators receive a six-month training course prior to their initial assignment. The first seven weeks consist of attendance at a programming school. The remaining weeks are spent in controlled on-the-job training in all phases of an ERMA Center's operation. All other employees are given on-the-job training in their respective assignments.

RELIABILITY, OPERATING EXPERIENCE, AND TIME AVAILABILITY

Average error-free running period	2 Hours
Good time	60 Hours/Week (Average)
Attempted to run time	62 Hours/Week (Average)
Operating ratio (Good/Attempted to run time)	0.967
Above figures based on period	1 Aug 60 to 31 Aug 60
Passed Customer Acceptance Test	1 Jul 59
Time is available for rent to qualified outside organizations. Although we have available computer time now, it is not being offered on a rental basis due to our projected volume which will utilize this time.	

ADDITIONAL FEATURES AND REMARKS

Outstanding features include magnetic ink character recognition and simultaneous read one tape, write one tape, and compute is permitted. Magnetic ink character recognition units on the sorter/readers allow computer input directly from source documents.

Magnetic tapes receive an internal label under program control as well as a manually produced external label. Tapes are stored in a fire-proof tape vault which has humidity and temperature control. Critical "back-up" tapes are sent daily to off-premise storage locations.

The system was designed by General Electric as a general purpose computer to be used primarily in deposit accounting. Therefore, in order to utilize source documents as immediate input, the system was provided with magnetic character recognition facilities rather than punched card input.

Components of a basic system are a central processing unit, main power unit, console, eight tape units, tape control unit, printer, printer control unit, three sorter/readers, and a sorter/reader control unit.

Under the term of the sales contract, cost/price figures per system will not be available prior to equipment acceptance at final installation.

FUTURE PLANS

Additional ERMA Centers are planned to service the branches of the Bank of America in the Sacramento, Fresno, West Los Angeles, Southwest Los Angeles, Montebello, and San Diego areas. It is anticipated that these centers will all be in operation by June 30, 1961.

Due to the fact that our ERMA Centers are either relatively new or still in the planning stage, and since the equipment has yet to be utilized to the maximum extent of which it is capable, no additional components, major modifications or plans for retirement are under consideration at the present time.

INSTALLATIONS

Bank of America NT & SA
Systems and Equipment Research Department
500 Howard Street
San Francisco, California

GE 210

General Electric Model 210

MANUFACTURER

General Electric Company
Computer Department

APPLICATIONS

Manufacturer

System is designed for general purpose, commercial, data processing and utility billing applications.
Computer Department, General Electric

System is used for banking, utility billing, and inventory

PROGRAMMING AND NUMERICAL SYSTEM

Manufacturer

Internal number system	Binary coded decimal
Decimal digits/word	6
Decimal digits/instruction	6
Instructions/word	1
Instructions decoded	124
Arithmetic system	Fixed point
Instruction type	One address
Number range	-999,999,999,999 to +999,999,999,999

Photo by General Electric Company

Instruction word format

	Operation Code		Operand Address			

There are automatic built-in subroutines. A complete library of subroutines for business data processing is available.

G. E. Com. and General Electric Common Language (Common to all G. E. Machines) including Automatic Coding Techniques and Assembly Compiler are available.

Registers

N	Location of next instruction
M	Input & output memory transfer
J	Memory Buffer
I	Contains current instruction
R	Accumulator

- L Used with R for double length word operations
- B Address portion on instruction
- P Peripheral Buffer

ARITHMETIC UNIT

Manufacturer		Incl. Stor. Access	Exclud. Stor. Access
		Microsec	Microsec
Add	64		32
Mult	550 Aug.		518
Div	1200 Aug.		1168
Construction (Arithmetic unit only)			
Transistors	9,998		
Condensers	7,430		
Diodes	39,333		
Arithmetic mode	Serial		
Timing	Synchronous		
Operation	Concurrent		

STORAGE

Manufacturer			
Media	No. of Words	No. of Digits	Access Microsec
Core Memory	4,000 or 8,000	24,000 or 48,000	32
Magnetic Tape	1,400,000	8,400,000	5000
No. of units that can be connected 13 Units			
No. of chars/linear inch 66 Chars/inch			
Channels or tracks on the tape 11 Tracks/tape			
Blank tape separating each record 1 Inch			
Tape speed 60 or 100 Inches/sec			
Transfer rate 30 to 50 KC Chars/sec			
Start time 4.5 Millisec			
Stop time 4.5 Millisec			
Average time for experienced operator to change reel 30 Seconds			
Physical properties of tape			
Width 3/4 Inches			
Length of reel 1200, 2400, 3600 Feet			
Composition Mylar			

INPUT

Manufacturer		Speed
Media		
Magnetic Tape		30 or 50 char/sec
Magnetic Documents		750 or 1200 documents/min
Paper Tape		200 or 500 char/sec
Punched Cards		400 or 1500 cards/min
Console Typewriter		10 char/sec

OUTPUT

Manufacturer		Speed
Media		
Magnetic Tape		30 or 50 char/sec
Magnetic Documents		750 or 1200 documents/min
Paper Tape		60 char/sec
Console Typewriter		10 char/sec
High Speed Printer		72 Column 600 (Alpha) lines/min
		1200 (Numeric) lines/min
		120 Column 600 to 1000 lines/min
		El3B Magnetic Font (off line)
		300 lines/min

CHECKING FEATURES

Manufacturer
Internal checking is performed on all operations by the Modulo-3 method.
A 2-way parity check is performed in all magnetic tape operations.

POWER, SPACE, WEIGHT, AND SITE PREPARATION

Manufacturer		
KVA, computer	10 KVA	208v
Area, computer	50 sq ft	
Room size	680 sq ft	
Floor loading	150 lbs	
Weight, computer	10,000 lbs	
Capacity, air conditioner	7 Tons	
Computer Department, General Electric		
KVA, computer	40 KVA	
Area, computer	1100 sq ft	
Floor loading	250 lbs concen max	
Weight, computer	9,650 lbs	
Weight, air conditioner	central	

Site preparation included a false ceiling and floor, and brick construction.

PRODUCTION RECORD

Manufacturer	
Number produced to date	8
Number in current operation	8
Number in current production	8
Number on order	50
Time required for delivery	12 - 15 months

COST, PRICE AND RENTAL RATES

Manufacturer		Cost
Basic system		
Central Processor		\$225,000

PERSONNEL REQUIREMENTS

Manufacturer
Entirely dependent on application and utilization.
Training made available by manufacturer to users includes complete training in all aspects of electronic data processing - programming classes, operator training, and consultation service. Full time site application engineer assigned to customer from time of order until 3 months after installation.
Computer Department, General Electric
One 8-Hour Shift

Supervisors	1
Analysts	2
Programmers	2
Coders	3
Clerks	8
Librarians	1
Operators	2
Engineers	4
Technicians	2
In-Output Oper	5

Operation tends toward open shop.

RELIABILITY, OPERATING EXPERIENCE, AND TIME AVAILABILITY

Manufacturer
Large scale computer fully transistorized and proven by 1 1/2 years of continuous daily operation in processing an actual application.
Computer Department, General Electric
Average error-free running period 95%
Good time 35 Hours/Week (Average)
Attempted to run time 40 Hours/Week (Average)
Operating ratio (Good/Attempted to run time) 95%
Passed Customer Acceptance Test June 59
Time is available for rent to outside organizations.

ADDITIONAL FEATURES AND REMARKS

Manufacturer

Outstanding features include automatic address modification, blockette write, table look-up command, special commands for internal sorting, and ease of programming.

Unique system advantages include dual document handlers on-line; automatic Mod-3 and parity check, and simultaneous read/write/compute ability.

Computer Department, General Electric

System is completely solid-state. It has the ability to read ABA El3B Font.

Magnetic tapes are stored in vaults and fireproof cabinets.

FUTURE PLANS

Manufacturer

Future plans for this system include thermo plastic tape storage, broader use of magnetic ink, and character reading.

INSTALLATIONS

General Electric Company
Computer Department
13430 North Black Canyon Highway
Phoenix, Arizona

GE 225

General Electric Model 225

MANUFACTURER

General Electric Company
Computer Department

APPLICATIONS

System is designed for business data processing, business paper processing, and scientific computing.

PROGRAMMING AND NUMERICAL SYSTEM

Internal number system	Binary
Binary digits/word	(19 + sign) = 20
Instructions/word	One
Instructions decoded	59 plus input and output
Arithmetic system	Floating point optional
	Fixed point standard
Instruction type	One address
Instruction word format	

4	5	6	7
Operation Code	Address Modification Bits		Operand Process

Automatic built-in subroutines include double precision add and subtract. Standard double precision multiply and divide are optional.

The standard GE 225 is equipped with a compiler which is an automatic coding technique which allows the program to be prepared with little or no knowledge of the intricacies or internal language of

Photo by General Electric Company

modern computers.

Registers

A Register	an accumulator
Q Register	used for double length operations
M Register	memory location
N Register	output register for typing
I Register	instruction register
B Register	memory buffer, holds information during arithmetic operations
P Counter	instruction counter

GE 225 accommodates alphabetic or numeric, binary or decimal information.

ARITHMETIC UNIT

	Incl. Stor. Access Microsec	Exclud. Stor. Access Microsec
Add	40	20
Mult	250	230
Div	500	480
Construction (Arithmetic unit only)		
Transistors	3,194	
Condensers	4,747	
Diodes	4,183	
Magnetic Cores	327,680	

Arithmetic mode Serial
 Timing Synchronous
 Operation Sequential

System is concurrent in that input-output equipment operates simultaneously with central processor, which performs calculations. This substantially reduces processing time.

STORAGE

Media	No. of Binary Words	Access Microsec
Magnetic Core	2048, 4096, 8192 or 16,384	20
Magnetic Drum	8192 or 16,384 20-bit words	8,300

Magnetic Tape

No. of units that can be connected	64 Units
No. of chars/linear inch	200 Chars/inch
Channels or tracks on the tape	7 Tracks/tape
Blank tape separating each record	3/4 Inches
Tape speed	75 Inches/sec
Transfer rate	15,000 Chars/sec
Average time for experienced operator to change reel of tape	30 Seconds
Physical properties of tape	
Width	1/2 Inch
Length of reel	2,400 or 3,600 Feet (Max)
Composition	Mylar

The tape language is compatible with most existing tape installations.

INPUT

Media	Speed
Magnetic Tape	15,000 char/sec
Horizontal and vertical parity checking	
Document Sorter	1,200 docum/min
Sorter under control of central processor	
Paper Tape Reader	1,000 char/sec
Parity check	
Card Reader	400 cards/min
Reads binary or Hollerith CD. Photoelectric Control Console	

OUTPUT

Media	Speed
Console Typewriter	10 char/sec
This is under the control of the central processor	
Card Punch	100 cards/min
Punches binary or Hollerith cards	
High Speed Printer	600 lines/min
Flexible print format-parity check	
Magnetic Tape	15,000 char/sec
Horizontal and vertical checking	
Punched Paper	60 char/sec
5, 6, 7, 8 channel tape	
Data Transmitter - Receiver Unit	60 char/sec

CHECKING FEATURES

Parity checking

POWER, SPACE, WEIGHT, AND SITE PREPARATION

KVA, computer	15
Room size	1,200 sq ft
Capacity, air conditioner	3 Tons
Weight, computer	8,900 lbs

PRODUCTION RECORD

Time required for delivery from receipt of order
12 months

COST, PRICE AND RENTAL RATES

	Cost
Basic System	
Central Processor	\$200,000 or \$4,000/mo.

PERSONNEL REQUIREMENTS

Entirely dependent on application and utilization. Training made available by manufacturer to users includes complete training in all aspects of electronic data processing - programming classes, operator training, and consultation service. Full time site application engineer from time of order until 3 mos. after installation.

ADDITIONAL FEATURES AND REMARKS

The data mating function of GE 225 provides a common control and inter-communication link for the wide range of either data processing peripheral units or unusual special purpose input-output devices associated with the system.

A general compiler provides the programmer with a highly advanced and effective automatic coding technique.

The equipment flexibility of the GE 225 offers an additional degree of freedom in the planning of a system by allowing the computer to grow to meet the demands of expanding systems requirements.

INSTALLATIONS

General Electric Company
 Missile and Space Vehicle Department
 3198 Chestnut Street
 Philadelphia 1, Pennsylvania

GE 250

General Electric 250 Information Searching Selector

MANUFACTURER

Computer Department
General Electric Company

Photo by Computer Department, General Electric Company

APPLICATIONS

The GE 250 Information Searching Selector is a data processing system specifically designed to provide rapid inquiry and selection from large data files.

In its simplest form, the Information Searching Selector provides: storage of information, storage of the search questions, and the means for comparing the two, detecting desired information, and recording the result.

The information file is stored on magnetic tape which provides a compact record with unlimited expansion. Search questions are stored in the memory of the Selector. Whenever search questions are satisfied, answers are recorded.

It can be used to retrieve information from vast files of data as found in: industry (chemicals,

metals, petroleums, pharmaceuticals), government (patents, military, personnel, intelligence, law enforcement, census), and the professions (law, medicine, applied research, libraries).

The first GE 250 Information Searching Selector will be delivered to the Center for Documentation and Communications Research at Western Reserve University. It will be used to accelerate the abstracting service of a metals information center now in operations, as well as to facilitate further effort into other documentation and library research - including language translation.

PROGRAMMING AND NUMERICAL SYSTEM

Up to ten inquiries may be prepared on punched paper tape and entered into the Selector's main memory for simultaneous processing. Successive reels of magnetic tape file are searched at the rate of 15,000 characters per second for satisfaction of any or all of the ten inquiries. Each tape may contain four million or more characters.

A printed text or identifying information is provided in answer to all selected questions and the search criteria they fulfill. If desired, acceptance through partial satisfaction of requirements can be specified.

The GE 250 Information Searching Selector retrieves selected information from a large storage file, permits immediate and efficient use of recorded knowledge, answers questions through high-speed electronic searching, correlates scattered information in complex files, reduces costs of file preparation and searching, and simplifies updating of information with new material - simplifies elimination of obsolete information.

ARITHMETIC UNIT

System reviews and compares 15,000 char/sec.

Several thousand abstracts can be processed per minute.

Up to ten unrelated inquiries can be searched simultaneously.

STORAGE

Magnetic Tape	15,000 char/sec
Buffer Storage	Expansible

Number of magnetic tape units is variable.

INPUT OUTPUT

Media	Speed
Magnetic Tape	15,000 char/sec
Cards	Read-punch unit

CIRCUIT ELEMENTS OF ENTIRE SYSTEM

System is fully transistorized.

CHECKING FEATURES

Adequate checking provides accuracy.

ADDITIONAL FEATURES AND REMARKS

The GE 250 Information Searching Selector can operate with any indexing, classifying or coding system-even simple English notation. Professional assistance will be provided for developing systems and adapting well-tested procedures.

Outstanding features are that it is compact, easy to install, and easy to operate. It requires little power as it is fully transistorized.

FUTURE PLANS

The first Information Searching Selector will be used by Western Reserve University, Center for Documentation and Communication Research, to provide rapid inquiry and selection of information from vast data files.

INSTALLATIONS

Western Reserve University
Center for Documentation and Communication Research
Cleveland, Ohio

General Electric Company
Computer Department
Deer Valley Park
Phoenix, Arizona

GE 312

General Electric Model 312

MANUFACTURER

General Electric Company
Computer Department

APPLICATIONS

System is designed for process and production control as well as for data logging and monitoring.

PROGRAMMING AND NUMERICAL SYSTEM

Internal number system Binary
 Binary digits/word 20 19 + Sign
 Binary digits/instruction 19
 Instructions/word Single address or 1+1 Mode
 Instructions decoded More than 60
 Arithmetic system Fixed point
 Instruction type One address
 Number range -524,288 to +524,288
 Instruction word basic format

1	2	5	6	19
Command			Operand Address	

An eleven bit automatic modification of instruction address is provided for automatic instruction

Photo by General Electric Company

modification, linkage for sub-routines, counters, etc.

Registers

A Primary Arithmetic Register
 Q Arithmetic and Temporary Storage
 N I/O Buffer
 X Instruction Modification
 X Current Instruction
 B Location of Next Instruction

ARITHMETIC UNIT

	Incl. Stor. Access Microsec	Exclud. Stor. Access Microsec
Add	192(1 Add) 288(1+1 Add)	96
Mult	2016 Max (1+1)	1920 Max
Div	2592 Max (1+1)	2496 Max
Construction (Arithmetic unit only)		
Transistors	2,572	
Condensers	1,409	

Diodes	2,265
Arithmetic mode	Serial
Timing	Synchronous
Operation	Sequential

STORAGE

Medium	No. of Words	Access Microsec
Magnetic Drum	2,048 to 50,000	6,250 avg
Optional: Fast Access Core Storage can be provided.		

INPUT

Media	Speed
Paper Tape Reader	20 char/sec
Standard equipment	
Paper Tape Readers	Up to 240 char/sec
Optional equipment.	Additional or alternatives.
Process Analog and Digital Information	
Requires optional equipment	

When coupled to process instrumentation, analog or digital inputs may be accommodated within limits which virtually are determined only by the requirements of the users.

OUTPUT

Media	Speed
Paper Tape Punch	20 char/sec
Standard equipment	
Electric Typewriter	10 char/sec
Standard equipment	
Paper Tape & Card Punch	60 char/sec
Optional	
Analog Output (Digital-to-Analog Converter)	

CIRCUIT ELEMENTS OF ENTIRE SYSTEM

Type	Quantity
Diodes	
HD2160	445
1HL692	32
HD2231	1,788
Transistors	
2N219	2,290
2N321	51
2N527	135
2N388	96

CHECKING FEATURES

Parity checking

POWER, SPACE, WEIGHT, AND SITE PREPARATION

Power, computer	4 Kw	120v ± 10%	60 cps
Volume, computer		168 cu ft	
Area, computer		27 sq ft	
Floor loading		110 lbs/sq ft	
Weight, computer		3,000 lbs	
Air conditioner		Self contained	
		105°C max, 95% humidity	

PRODUCTION RECORD

Number produced to date	4 (1 Aug 60)
Number in current operation	4
Number in current production	12
Number on order	12
Time required for delivery	8-12 months

COST, PRICE AND RENTAL RATES

GE 312 Digital Control Computer System
Standard Basic Price with 8,000 word drum memory \$85,200

In usual applications the GE 312 is used as Central Processor for On Line Data Processing & Computer Control Systems for utility & industrial plants, depending upon the system configuration.

Price range from	
\$150,000 to	
\$500,000	

PERSONNEL REQUIREMENTS

Completely dependent upon application. Training made available by manufacturer to users includes a 3 week programming course and an 8 week maintenance course. Following the 3 and 8 week courses, is on-site training during installation and initial operation.

RELIABILITY, OPERATING EXPERIENCE, AND TIME AVAILABILITY

On-Line reliability of 99% over a 6 month period.

ADDITIONAL FEATURES AND REMARKS

Outstanding features include up to 52,000 word drum memory expansion, single & 1 + 1 address, and automatic address modification.

Unique system advantages include a flexible command structure, including a special instruction for computer direction of system input/output equipments.

GENERAL MILLS AD/ECS MANUFACTURER

General Mills AD/ECS Computer

General Mills
Mechanical Division

APPLICATIONS

System is a general purpose digital computer, which may be used for on-line and real time applications as well. System can communicate with conventional digital I/O, as well as A/D converters, and other buffering equipment.

PROGRAMMING AND NUMERICAL SYSTEM

Internal number system	Binary
Binary digits/word	36 + sign
Binary digits/instruction	18
Instructions per word	2
Instructions decoded	Up to 64
Arithmetic system	Fixed point (Floating optional)
Data processing is in alphanumeric	
Instruction type	One address
Number range	- (1-2 ⁻³⁶) through + (1-2 ⁻³⁶)

Photo by General Mills

Instruction word format

Break-point	Instr I		Instr II	
	Oper	Address	Oper	Address
1	6	12	6	12

Instructions are not permanently designed into the machine, but are constructed from microprogrammed "instructions" by means of placing appropriate diode logic on a special circuit card called an "instruction card". Many specialized orders can be constructed using this technique.

One index counter is standard. There are up to 8 additional index counters available as an option.

Photo by General Mills

ARITHMETIC UNIT

	Incl Stor Access Microsec	Exclud Stor Access Microsec
Add	80	60
Mult	840	800
Div	940	920
Construction (Arithmetic unit only)		
Transistors	1,000	
Diodes	10,000	
Arithmetic mode	Parallel	
Timing	Asynchronous	
Operation	Sequential	
System is entirely solid state.		

No. of chars/linear inch of tape	200 Chars/inch
Channels or tracks on the tape	7 Tracks/tape
Blank tape separating each record	0.75 Inches
Tape speed	150 Inches/sec
Transfer rate	30,000 Chars/sec
Start time	5 Millisec
Stop time	5 Millisec
Average time for experienced operator to change reel of tape	60 Seconds
Physical properties of tape	
Width	0.5 Inches
Length of reel	2,100 Feet
Composition	3M 186 magnetic instrumentation tape

STORAGE

Media	No. of Words	No. of Digits/Word	Access Microsec
Magnetic Core	4,096	36 bits + sign	8
Magnetic Drums (optional)	10,000	36 bits + sign	8,000 (avg)
Magnetic Tape	No. of units that can be connected 64 Units		

INPUT

Media	Speed
Paper Tape	150 char/sec
Typewriter	12 char/sec
Paper tape is standard but computer can also accommodate a wide variety of other input devices, e.g. cards. Unit will read any code one 8 bit character at a time or std word or block.	

OUTPUT

Media	Speed
Paper Tape	60 char/sec
Typewriter	12 char/sec

Paper tape is standard but computer can also accommodate a wide variety of other output devices, e. g. cards, printers. Unit will punch any code one 8 bit character at a time or std word or block. Alpha-numeric with format control.

Paper tape units will handle data in any format up to 8 levels. System is capable of handling up to 64 input-output devices of almost any sort. These devices could exchange information with two 64-word magnetic core buffers at the normal input-output device information rate. The central computer initiates these external machine and buffer operations but does not wait for their execution. The AD/ECS goes on with other computation while buffer operations are proceeding and then takes in the buffer information at the central computer rate.

CIRCUIT ELEMENTS OF ENTIRE SYSTEM

Type	Quantity
Diodes	15,000
Transistors	1,500
Magnetic Cores	37,000; 74,000; or 148,000

System is entirely solid state. Quantity of magnetic cores is dependent upon the memory option.

CHECKING FEATURES

Parity check on all input-output. Marginal checking on frequencies and voltages.

POWER, SPACE, WEIGHT, AND SITE PREPARATION

Power, computer	1 Kw
Volume, computer	65 cu ft
Area, computer	10.5 sq ft (not including console)
Floor loading	60 lbs/sq ft
Weight, computer	600 lbs

No special site preparation or air conditioning required.

PRODUCTION RECORD

Number produced to date	2
Number in current operation	2
Number in current production	1
Number on order	1
Time required for delivery	6 months

COST, PRICE AND RENTAL RATES

Basic System	Cost
Paper Tape Reader (150 char/sec)	\$ 3,932
Paper Tape Punch (60 char/sec)	3,283
Central Computer	109,956
Typewriter	12,952
Console plus Desk	11,857
	Total \$ 141,980
Additional Equipment	
Floating point	\$ 3,200
Extra index, counters: 1 through 4	760 plus
	1,930 each
	5 through 8
	1,520 plus
	1,930 each
Binary to BCD and BCD to binary instruction cards	155 each
Bin to alphanum and alphanum to bin instruction cards	205 each

Not available for rent.

On-site or on-call maintenance is available.

PERSONNEL REQUIREMENTS

Programming and, if desired, maintenance training courses are available. Personnel requirements depend on application and size of system.

RELIABILITY, OPERATING EXPERIENCE, AND TIME AVAILABILITY

Completely transistorized. Designed to work without air-conditioning in range of 32° F - 125° F. System constructed of very few basic building blocks. Has operated reliably outdoors for extended (months) periods.

ADDITIONAL FEATURES AND REMARKS

Outstanding features include the ability to have extremely flexible order structure, due to instruction card principle, flexible external machine communications, magnetic core I/O buffers, and air-conditioning is not required.

Unique system advantages include special instruction for individual requirements without any modification of the computer, and ease of addition of a wide variety of peripheral equipment without computer modification.

FUTURE PLANS

Continued development of I/O equipment.

INSTALLATIONS

General Mills
Mechanical Division
2003 East Hennepin Avenue
Minneapolis 13, Minnesota

GENERAL MILLS APSAC

General Mills APSAC Computer

MANUFACTURER

General Mills
Mechanical Division

Dust Covers Removed

Photo by General Mills

APPLICATIONS

General purpose computer used in on-line automatic survey system.

Explanation of last three bits in each instruction

Address A Reg.	Clear A Register	Breakpoint
-------------------	---------------------	------------

First two bits in this group are not used by every instruction.

Registers include an accumulator register (A) and a remainder register (R).

PROGRAMMING AND NUMERICAL SYSTEM

Internal number system Binary
 Binary digits/word 35 (plus sign)
 Binary digits/instruction 18
 Instructions per word 2
 Instructions decoded 29
 Arithmetic system Fixed point
 Instruction type One address
 Number range 2^{-35} to 2^{+35}

Instruction word format 36 bits

6	12	3	6	12	3
Oper	Address		Oper	Address	

ARITHMETIC UNIT

	Incl Stor Access Microsec	Exclud Stor Access Microsec
Add	120	120
Mult	1,520	1,500
Div	16,200	Done by sub routine

Construction (Arithmetic unit only)
 Transistors Approx 1,200
 Condenser-Diodes Approx 16,000
 Magnetic Cores Approx 20,000
 Arithmetic mode Parallel
 Timing Synchronous
 Operation Sequential

STORAGE

Medium	No. of Words	No. of Digits	Access Microsec
Magnetic Core	512	35 + sign	10
Magnetic Tape			
No. of units that can be connected			2 Units
No. of chars/linear inch			48 Chars/inch
Channels or tracks on the tape			7 Tracks/tape
Blank tape separating each record	0.667		Inches
Tape speed			25 Inches/sec
Transfer rate	1,200		Chars/sec
Start time			3 Millisec
Stop time			3 Millisec
Average time for experienced operator to change reel of tape			60 Seconds
Physical properties of tape			
Width			0.5 Inches
Length of reel	approx		300 Feet
Composition			Mylar

INPUT

Medium	Speed
Flexowriter	10 chars/sec

OUTPUT

Medium	Speed
Flexowriter	10 chars/sec
Typewriter and punch	

System has, in addition to Flexowriter and magnetic tape, real-time input from digital clock and from astrolabe.

CIRCUIT ELEMENTS OF ENTIRE SYSTEM

Type	Quantity
Diodes	20,000
Transistors	1,500
Magnetic Cores	20,000

CHECKING FEATURES

Magnetic tape has parity check across tape, and markers for usable and non-usable tape. Paper tape also has parity check.

POWER, SPACE, WEIGHT, AND SITE PREPARATION

Power, computer	0.86 Kw	0.96 KVA	0.9 pf
Volume, computer	52 cu ft		
Area, computer	15 sq ft		
Floor loading	35 lbs/sq ft		
	35 lbs concen max		
Weight, computer	520 lbs		
No special site preparation or air conditioner needed.			

PRODUCTION RECORD

Number produced to date	1
Number in current operation	1
Number in current production	Now in field test
Number on order	Now in field test
Time required for delivery	6 months

PERSONNEL REQUIREMENTS

Operator, programming, and maintenance courses are optional. Ordinarily GMI trains maintenance personnel, although it can be handled on contract basis if desired.

RELIABILITY, OPERATING EXPERIENCE, AND TIME AVAILABILITY

Both computer and magnetic tape equipment designed to operate under field conditions. Average operating time between component failures is about 600 hours.

FUTURE PLANS

Anticipate repackaging to minimize space requirements.

INSTALLATIONS

General Mills Mechanical Division
 1620 Central Avenue
 Minneapolis 13, Minnesota

GEORGE

Argonne National Laboratory "GEORGE" Computer

MANUFACTURER

Argonne National Laboratory

APPLICATIONS

Scientific problems.
Data handling and data reduction.

PROGRAMMING AND NUMERICAL SYSTEM

Internal number system	Binary
Number of binary digits per word	40 or 80
Number of binary digits per instruction	20 to 100
Number of instructions per word	Variable
Total number of instructions decoded	2 ²⁰
Arithmetic system	
Floating Point	Fixed Point
Sign + 62 bit fraction	Sign + 39 bit fraction
Sign + 10 bit power	20 bit positive integers
6 bit index of significance	
Instruction type	Modified two-address for fixed point Variable zero through four-address for float- ing point
Number range	
Fixed Point	$-1 < n \leq 1-2^{-39}$
Floating Point	$[-1/2 \leq c \leq +1/2] [2^{-1024} \leq e \leq 2^{+1024}]$

Photo by Argonne National Laboratory

Instruction word format

B-Address	Order	Tag	A-Address
0 - 11	12 - 19	20 - 27	28 39

Order	A-Address	B-Address	C-Address	D-Address
0 - 19	20 - 39	40 - 59	60 - 79	80 - 99

Automatic built-in subroutines
 Square root on floating point
 Automatic coding
 GAR - George Assembly Routine (with Macro-instructions)

Registers and B-boxes
 Fixed and floating point arithmetic registers
 Four high speed floating point registers
 16 high speed index registers and any memory location

An index of significance is carried with each floating point number and is corrected with each operation as to the number of bits which are still significant.

Photo by Argonne National Laboratory

ARITHMETIC UNIT

Operation time, excluding storage access, Microseconds	Microseconds	
	Fixed Point	Floating Point
Add	7	3
Mult	485	26
Div	595	27
Construction, arithmetic unit only		
Vacuum tubes	1,800	
Transistors	20,000	
Crystal diodes	6,000	
Arithmetic mode	Parallel	
Timing	Asynchronous	
Operation	Concurrent	

GEORGE is composed of two arithmetic units, a fixed point unit and a floating point unit. Each has its own word length and instruction code. The two arithmetic units work concurrently with a single memory.

STORAGE

Media	Number of Words	Number of Digits	Access Microseconds
Magnetic core	4,096	42 bits/word	7.5
Wide magnetic tape	4×10^6	42 bits/word	
Magnetic tape system features are:			
Maximum number of units that can be connected to the system			4 Units
Channels or tracks on the tape			42 Track/tape
Tape speed			43 Inches/sec
Physical properties of tape			
Width			2 Inches
Length of reel			1200 Feet
Composition			Mylar Sandwich
Tape has fixed blocks of 128 words. The time per block is 70 millise: Including start, read or write, and stop. Tape may be searched for a particular block while the computer is computing.			

INPUT

Media	Speed
Paper tape (2 readers)	1,000 alphanumeric char/sec
Narrow mag tape	15,000 alphanumeric char/sec
Keyboard	Manual

OUTPUT

Media	Speed
Paper tape	60 alphanumeric char/sec
Narrow mag tape	15,000 alphanumeric char/sec
Buffered 16 microsecond tieup for computer	
On-line printer	72 columns; 600 lines/minute
Buffered 28 microsecond tieup for computer	
Console typewriter	10 char/sec
Cathode ray tube	

CIRCUIT ELEMENTS OF ENTIRE SYSTEM

Tubes	Quantity
Type 5670	70% of 3,500
Diodes	
1N191	30% of 6,000
1N628	20% of 6,000
S55G	50% of 6,000
Transistors	
2N393	85% of 20,000
Magnetic cores	164,000

CHECKING FEATURES

Parity on Input, Output, and Core memory.
Complete redundancy and Dropout error.
Correction on wide magnetic tapes.

POWER, SPACE, WEIGHT, AND SITE PREPARATION

Power, computer 50 K.W.
Air conditioner part of building system.

PRODUCTION RECORD

Number produced to date 1
Number in current operation 1

Floating point is under construction. Completion date is 31 December 1960. Fixed point has been in operation since September 1957.

PERSONNEL REQUIREMENTS

	Two 8-Hour Shifts
Supervisors	3
Analysts	3
Programmers	15
Clerks	2
Librarians	1
Operators	2
Engineers	1
Technicians	2
In-Output Oper	2

Description of the order structure and the programming systems available are found in ANL-5995, GEORGE Programming Manual by Loretta Kassel.

RELIABILITY, OPERATING EXPERIENCE, AND TIME AVAILABILITY

Fixed Point GEORGE has been operating two and 1/2 years with an average effective time over 80%. In the past year the effective time has been about 90%.

ADDITIONAL FEATURES AND REMARKS

Outstanding Features:

1. FLIP (Floating Point Unit) numbers have index of significance, i.e. an indication of how many significant bits remain in the number.
2. In fixed point (GEORGE) the first 12 bits of any memory location can be used as an index register. Thus, 4096 "index registers" are available.
3. In fixed point operations, GEORGE Instructions 2-nd address (B-address) has a variety of uses, it can be used as an index address, a "preliminary add" address, a store address, and/or a jump address.

Unique System Advantages:

1. Flexibility of B-address allows for compact coding - to make for better use of the 4096 word memory in fixed point operations.
2. Length of floating point word, and the index of significance, allow for more accuracy in floating point operations.

INSTALLATIONS

Argonne National Laboratory
9700 Cass Avenue
Argonne, Illinois

FUTURE PLANS

Present plans call for a 128,000 word drum and for a larger, faster core memory.

GEOTECH AUTOMATIC MANUFACTURER

Geotechnical Automatic Chart Reader

The Geotechnical Corporation

APPLICATIONS

System reads information contained on plotted charts, converts into several forms of output, and performs simultaneous computations, digital or analogue. The recorded charts are scanned optically, output is produced proportional to trace ordinate, and operations are performed on the output.

So many different sizes and configurations of charts and films are recorded by such a variety of techniques that no one instrument configuration could possibly be designed to read them all. However, the basic techniques, utilizing the BASIC READER, the CONVER-

Photo by the Geotechnical Corporation

SION UNITS, or the COMPUTING UNITS, can be applied successfully to many unusual types of charts and films. A drive system for the chart is often obtained by employing a drive similar to the one on which the chart was originally recorded. For best results, the trace on the chart should have good contrast with the chart paper. For example, a BASIC READER, with the digital computer, reads year-long river and stream water level charts, feeds the computer which computes daily mean discharge and water level, and reads out to punched tape, then automatic typewriters.

PROGRAMMING AND NUMERICAL SYSTEM

Computations are performed with modular computing units. Rack mounted computing units may be added in building block fashion. Computing units perform integration, multiplication, addition, subtraction, reciprocal, variable functions and others.

INPUT OUTPUT

The BASIC READER consists of an optical projection system, a scanning system, and electronic circuitry. It is located so that a thin strip of light, focused on the chart at right angles to the long axis of the chart, reflects a narrow cross-sectional image of the chart onto a rotating scan disk. The dark trace of the chart does not reflect light; however, the white paper background on either side of the trace does reflect. Therefore, the strip of light imaged on the scan disk appears to be broken by a dark "spot." When the drive is turned on and the chart is set into motion, this spot undulates back and forth across the surface of the disk exactly as the trace undulates on the chart. The rotating scan disk is made of glass with an opaque coating through which two or more transparent slits have been scribed. These scribed slits are usually in the form of involute curves because a rotating involute provides a linear sweep and always intersects the strip of light from the chart at right angles. The type and number of slits scribed on the scan disk, as well as the rotational speed of the disk itself may vary according to particular requirements, however a speed of 3600 RPM and two involutes are common. As the disk rotates and its involute slit first intersects the strip of light imaged on it, light is allowed to pass through the slit to strike a photomultiplier tube. As rotation continues, the involute next intersects the dark spot, i.e. the reflected trace, and light to the photomultiplier is momentarily cut off, generating a pulse. A reference trace on the chart or reference marks on the disk are often used to generate another pulse which defines the base of the chart. A gating circuit then forms a measuring pulse whose duration is proportional to the spacing of these two pulses, and therefore proportional to the ordinate of the recorded trace. By rotating the disk containing the two slits at 3600 RPM, the location of the ordinate of the trace is pin-pointed 7200 times a minute. This system provides a continuous or periodic pulse-width output proportional to the trace ordinate of the moving chart, accurate to $\pm .1\%$ of full scale, and this output is all that is required for many purposes, however, additional outputs are available with modular conversion units. By adding optional rack-mounted conversion units in building-block fashion, the basic pulse-width output may be converted to digital, analog voltage or current, or mechanical rotation or displacement.

POWER, SPACE, WEIGHT, AND SITE PREPARATION

Power, computer	1 Kw
Volume, computer	16 cu ft
Weight, computer	300 lbs

COST, PRICE AND RENTAL RATES

\$10,000 for analog
\$20,000 for digital
Maintenance contract is available

PERSONNEL REQUIREMENTS

One operating technician is required. He can be taught on-the-job.

RELIABILITY, OPERATING EXPERIENCE, AND TIME AVAILABILITY

Good time	150 Hours/Week (Average)
Attempted to run time	180 Hours/Week (Average)

ADDITIONAL FEATURES AND REMARKS

	SPECIFICATIONS
Chart Drive	Synchronous motor
Chart Speed	12" per minute. Others available upon request.
Scan Rate	120 scans per second. Approximately 600 scans and PWM pulses per linear inch of chart at speed of 12" per minute.
Accuracy	PWM pulses proportional to trace ordinate are accurate to within $\pm 0.1\%$ of full scale. Analog voltage output proportional to trace ordinate is accurate to within $\pm 1\%$ of full scale.
Output	This model: 1 MA into 40 K ohms, designed to match a TI recti/riter recorder.
Power Requirements	500 VA, 115 volts, 60 cps.
Dimensions	24" deep; 24" wide; 50 1/2" high.
Weight	250 lbs (115 kg.)
Chart Requirements	This model is designed to read 6" rectilinear, single-trace charts.
Extraneous Marks	Charts must be free from marks that will produce spurious signals.
Trace	Continuous black line at least .020" wide.
Trace Contrast	Trace should have good contrast with chart paper.
Grid Lines	Preferably none; watery-green grid lines acceptable.

HAMPSHIRE CCC 500

Coordinate Conversion Computer Model 500

MANUFACTURER

Hampshire Engineering Company

Photo by Hampshire Engineering Company

APPLICATIONS

Computer is used with automatic tracking theodolites to give real time display and rapid tabula-

tion of aircraft position in rectangular coordinates.

PROGRAMMING AND NUMERICAL SYSTEM

Internal number system	Binary
Binary digits/word	20
Arithmetic system	Fixed point
Instruction type	Wired program
Number range	Fractional

Automatic built-in subroutines include translation of binary to binary coded decimal excess 3.

ARITHMETIC UNIT

	Incl. Stor. Access Microsec	Exclud. Stor. Access Microsec
Add	428	428
Mult	8500	8500
Div	8000	8000

Construction (Arithmetic unit only)

Vacuum-tubes, magnetic cores, and diodes	
Arithmetic mode	Serial
Timing	Synchronous
Operation	Concurrent

Arithmetic functions are performed concurrently by several small units connected directly with magnetic storage registers. Diode logic and vacuum tube amplifiers are used.

STORAGE

Medium	No. of Words	No. of Digits
Core-Diode Shift Registers	9	22

Magnetic tape used for output only.

INPUT

Input is by cable connection to shift registers in theodolites, and is in the form of binary coded pulse trains.

OUTPUT

Media	Speed
Analogue Voltages for X, Y, Z	Real time
Used by plotting board	
Punched tape	60 char/sec
Feeds ELECOM 120 Computer or Flexowriter	
Magnetic tape	2 & 4 in/sec
X, Y, Z in serial form. X, Y, and Z refer to rectangular coordinates.	

CIRCUIT ELEMENTS OF ENTIRE SYSTEM

Type	Quantity	
Tubes	98	in computer
	66	in output units
Diodes	Approx 1,000	
Magnetic Cores		
SR-100	450	

CHECKING FEATURES

Checking features include built-in marginal checking and built-in test problem input and output monitor.

POWER, SPACE, WEIGHT, AND SITE PREPARATION

Power, computer	1.0 Kw
Volume, computer	38 cu ft
Area, computer	7 sq ft
Room size	Any room
No special site preparation requirements.	

PRODUCTION RECORD

Number produced to date	1
Time required for delivery	6 months

COST, PRICE AND RENTAL RATES

Computer only	Approx \$50,000
Computer with output equipment	Approx \$80,000

PERSONNEL REQUIREMENTS

No special operators needed. Equipment can be operated by one man after a few hours' checkout. Service easily handled on part-time basis by one engineer or senior technician.

RELIABILITY, OPERATING EXPERIENCE, AND TIME AVAILABILITY

Simplicity is obtained by semi-permanently wiring computer to perform a specific problem solution.

Magnetic core storage driving diode logic directly reduces active elements and increases reliability. Dynamic pulse techniques used.

Total failures to date consists of 4 diodes, 1 resistor, and 3 printed circuit board connections. This covers a period of 3 years.

ADDITIONAL FEATURES AND REMARKS

Outstanding features include speed ample for real-time uses, computer is very simple with high reliability, and is unusually accurate in analogue output.

FUTURE PLANS

This system is being superseded by Model 932 Computer, which is faster, is more flexible, has greater capacity, and uses transistors rather than tubes.

HAMPSHIRE TRTDS 932

Hampshire Theodolite Real Time Display System
Model 932

MANUFACTURER

Hampshire Engineering Company

APPLICATIONS

The real time computer and display system is used with Contraves Phototheodolites to produce precision plots and tabulation of aircraft position in rectangular coordinates. It can also be used for radar coordinate conversion and other real time problems with appropriate problem changes.

PROGRAMMING AND NUMERICAL SYSTEM

Internal number system	Binary
Binary digits/word	22
Binary digits/instruction	Wired problem
Arithmetic system	Fixed point
Instruction type	Wired problem
Number range	22 bits (Fractional, incl. sign)

Automatic built-in subroutines include sine, cosine, tangent and translation of binary to binary coded decimal.

ARITHMETIC UNIT

	Incl. Stor. Access	Exclud. Stor. Access
	Microsec	Microsec
Add	220	220
Mult	1760	1760
Div	5300	5300
Construction (Arithmetic unit only)		
Transistors	85	
Magnetic Cores	165	Core-transistor shift registers
Arithmetic mode	Serial	
Timing	Synchronous	
Operation	Concurrent	

STORAGE

Medium	No. of Words	No. of Dig/Word
Core-Transistor Shift Register	15-easily expanded	22

INPUT

Media	Speed
Magnetic Tape	Real time
Telephone Lines	Real time

Telephone lines connect to the theodolites.

OUTPUT

Media	Speed
30" x 30" Plotting Board	Real time
Magnetic Tape	Real time
Punched Tape	1/3 real time
Flexowriter	1/10 real time
Analogue Voltages for X, Y, Z	Real time

CIRCUIT ELEMENTS OF ENTIRE SYSTEM

Type	Quantity	Use
Tubes	65	Output units
Diodes	3,000	
Transistors	500	Computer
	400	Auxiliary equipment
Magnetic Cores	650	Computer
	450	Auxiliary equipment

All figures are approximate. The computer cores are in the core-transistor shift register.

CHECKING FEATURES

Checking features include built-in marginal checking, built-in test problem inputs and output monitor, and parity check on data transmission.

POWER, SPACE, WEIGHT, AND SITE PREPARATION

Power, computer 1.5 Kw, approx
Power includes auxiliary equipment.

PRODUCTION RECORD

Number in current production	1
Number on order	1
Time required for delivery	Approx 6 months

COST, PRICE AND RENTAL RATES

Computer	\$50,000 to \$100,000
Complete system	\$100,000 to \$250,000

PERSONNEL REQUIREMENTS

	One 8-Hour Shift	Two 8-Hour Shifts	Three 8-Hour Shifts
Operators	1	2	3
Engineers	1/4	1/4	1/2
Technicians	1/2	1	1

RELIABILITY, OPERATING EXPERIENCE, AND TIME AVAILABILITY

Simplicity is obtained by semi-permanently wiring computer to handle a specific problem. Extremely conservative design is used. Magnetic cores are used for storage. Cores drive diode logic directly, thereby reducing number of active elements. A modified dynamic pulse technique with magnetic cores is used.

ADDITIONAL FEATURES AND REMARKS

Outstanding features include ample speed for real time use, simplicity with high reliability, operability by personnel with minimum training and unusual accuracy in analogue output.

INSTALLATIONS

Hampshire Engineering Company
2300 Washington Street
Newton Lower Falls 62, Mass.

HONEYWELL 290

Honeywell Computer Model 290

MANUFACTURER

Minneapolis-Honeywell Regulator Company
Special Systems Division

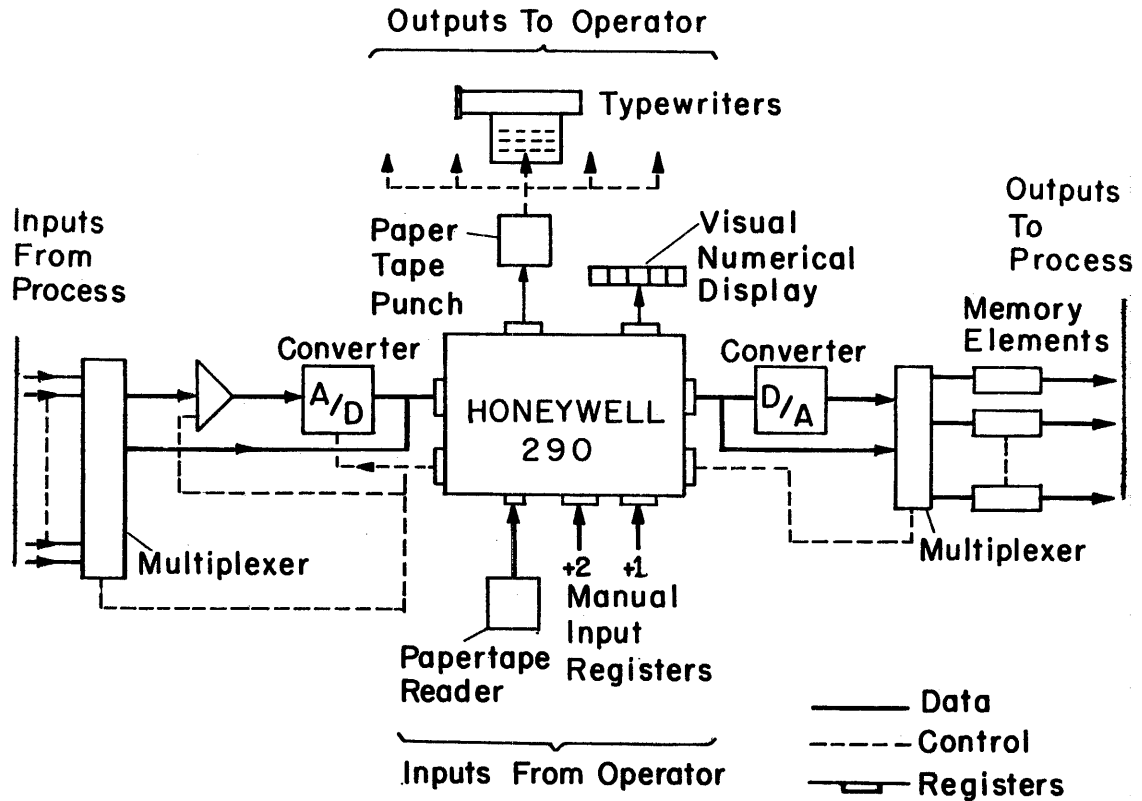

Photo by Minneapolis-Honeywell Regulator Company

APPLICATIONS

The Honeywell 290 Computer is a general purpose, internally stored program digital computer especially designed for use as a highly reliable on-line computer for process or operation monitoring and-or control. The H290 features all solid state circuitry, high speed, low clock rate, both core and drum memory, concurrent input, output and compute operation. The H290 can be furnished with over 70 instructions selectable by the user from a list of over 150 available instructions. The H290 Computer with associated

peripheral equipment can accept over 4,000 inputs at scanning speeds up to 1,000 points per second, perform calculations in real-time and produce over 4,000 outputs.



HONEYWELL INDUSTRIAL DIGITAL COMPUTER CONTROL SYSTEM DIAGRAM

Diagram by Minneapolis-Honeywell Regulator Company

PROGRAMMING AND NUMERICAL SYSTEM

Internal number system	Binary or Bin. Coded Dec.
Binary digits/word	18 Binary or 4 1/2 decimal
Binary digits/instruction	18 Binary
Instructions per word	One
Instructions decoded	Variable - any 70 or so out of over 150
Arithmetic system	Floating point
Can be provided as single instructions	Fixed point
Fractional (2's complement arithmetic)	
Instruction type	One address
6 bit operation code and 12 bit address. Several complex orders use two words as a single order.	
Number range	0 to 262, 143 in Binary and 0 to 39,999 in Binary-Coded-Decimal

Instruction word format

6 bits	12 bits
Operation Code	Address
18	12
13	1

There is no need for "built-in" subroutines. A group of 80 micro-instructions are assembled into macro macro-instructions dependent upon the Control Section logic. These macro-instructions may be changed with

comparative ease. A Control Section will be supplied according to the application and the user's desires and it can be modified or changed if the need arises.

Assembly routines are provided.

The H290 utilizes over 26 registers. Three are for inputs, 5 for outputs, 1 for instruction sequence, 4 for arithmetic and the balance for other internal computer functions. The entire core memory could be utilized as index registers.

The basic operation code consists of 6 bits, 64 orders involving memory addresses. A "no-address" type of order allows for 64 additional orders not involving variable addresses. If additional orders involving memory are required, the Control Section may be easily modified to utilize a "no-address" order as one addressing memory. The Control Section by being mostly magnetic, can have its entire order structure completely altered if desired. Because it is not conceivable that any one application would have need of the complete possible instruction vocabulary, it can be said that the number of available instructions is limitless for a particular application.

ARITHMETIC UNIT

	Incl Stor Access to both Oper- ands & "Housekeep- ing"	Incl Stor Access to One Operand & "Housekeep- ing"	No Access to Operands and No "House- keeping"
Operation	Microsec	Microsec	Microsec
Add	200	140	100
Mult	860	800	760
Div	1420	1360	1320

"Housekeeping" consists of those portions of each order that are identical for all orders and it accounts for 40 microseconds.

Construction (Arithmetic unit only)

Transistors	500 approx.
Diodes	1,500 approx.
Arithmetic mode	Parallel

2's complement arithmetic is used throughout which allows a powerful but comparatively simple add net work. No special logic is needed to handle sign determination. Arithmetic is completely binary with a relatively simple decimal translator for addition and subtraction. Binary-to-Decimal and Decimal-to-Binary conversion orders are provided for complete flexibility.

Timing

The basic clock frequency of 50 kc is realized through use of an asynchronous logical clock of six unique time periods each of which is independently variable.

Operation

Instructions are executed in sequence but input, output and internal computations are easily realized simultaneously. The computer itself is synchronized by the clock, but the clock is not an oscillator or multivibrator. A basic timing device and logic manipulator have been combined into the Primary Clock which can have no false moves. Separate Core Memory and Drum Memory Clocks are synchronized by the Primary Clock.

STORAGE

Media	No. of Words	No. of Digits (Max)	Access Microsec
Magnetic Core	1,024; 2,048; or 4,096	Binary 73,728 Decimal 16,384	20
Drum	4,096 or 8,192	Binary 147,456 Decimal 32,768	1700 Avg

Drum capacity is expandable to 32,000 words. Drum successive locations will require only 128 microseconds up to a maximum of 252 words. The first word of a series will average 1700 microseconds.

INPUT

Media	Speed
On-line from Analog-to-Digital Converter or from Digital Inputs directly	Up to 10,000 18-bit char/sec
Manual Dials	Approx 60 microsec per setting of the dials
Funched Paper Tape	20 char/sec

For real-time on-line acquisition of process measurements.

For occasional entry of new fixed information or new instructions.

Primarily for Program Loading.

OUTPUT

Media	Speed
On-line to Digital-to-Analog Converter or to Digital Devices	Up to 10,000 18-bit char/sec
Numerical Display Lights	For real-time on-line control of process variables or for actuating alarms, on-off devices, etc.
Punched Paper Tape	Up to 60 char/sec
On-line Digital	Up to 10,000 18 bit char/sec

For subsequent feed to electric typewriters

Two paths for selection of Input and Output Channels.

By means of a unique order structure and proper programming, it is possible to interlace an input program, an output program and a computation program. The input program will initiate input commands to peripheral devices and then switch control to the computation program. The computation program will periodically check to see if the input device has completed its conversion. When complete, the input program may then call for the next input and then jump to the output program. An output command may then initiate action by an appropriate output device and then jump to the computation program. This may be considered as a form of "traffic control". Proper programming prevents a series of input and output commands from "backing up" and virtually eliminates any waiting time for peripheral devices. The order structure enables the checking of peripheral devices for the completion of their last task and upon completion another command is issued to the peripheral device and the program can then immediately branch to another routine, periodically checking for the completion of the latest command issued to the peripheral device. The manner in which this is achieved by the program is quite simplified and flexible. Input and output channels are selectable by the twelve address bits of the input or output instruction thereby enabling the selection of any one of 4,096 inputs or 4,096 outputs.

CIRCUIT ELEMENTS OF ENTIRE SYSTEM

Type	Approx Quantity
Diodes	9,000
Transistors	1,500
Magnetic Cores	75,000

CHECKING FEATURES

Due to the nature of the applications on which this computer is intended to be used there is no requirement for parity checks nor checking bits associated with any word. Programmed system self checks and input and output reasonableness checks can be easily incorporated into the complete program. Particular types of checking can be incorporated in the order structure as a part of the Control Section on special order at additional cost. Simple program checks and verifying diagnostic routines can easily be incorporated in the complete program.

POWER, SPACE, WEIGHT, AND SITE PREPARATION

Power, computer w/air cond	1.4 Kw	2.3 KVA	0.6 pf
Power, air conditioner	0.3 Kw	1.1 KVA	
Volume, comp w/air cond		56 cu ft	
Area, comp w/air cond		8 sq ft	
Room size		10 ft x 10 ft	
Floor loading		144 lbs/sq ft	

Load is uniformly distributed over rectangular 2 ft x 4 ft frame with 1 5/8 inch frame width.

Capacity, air conditioner 0.5 Tons

The H290 is designed for industrial use and therefore no extreme site preparation is required. The air conditioner is built in.

PRODUCTION RECORD

Time required for delivery from receipt of order 12 to 18 months.

COST, PRICE AND RENTAL RATES

For 1 Honeywell 290 Computer with 4,096 words of core memory and 8,192 words of drum memory, 1 Paper Tape Reader, and 1 Paper Tape Punch, the selling price is approx. \$170,000.

Electric typewriters or printers, analog-to-digital converter, digital-to-analog converter, multiplexers, operator console(s), and control amplifiers are available. The selling price of total system, including additional equipment, varies, depending upon the application requirements. Various leasing and maintenance arrangements are available.

PERSONNEL REQUIREMENTS

Maintenance, programming and operator training are provided according to the purchaser's requirement.

RELIABILITY, OPERATING EXPERIENCE, AND TIME AVAILABILITY

The H290 Computer has been designed for maximum reliability and 100% availability for continuous operation. The "mean time between failures" is well over a thousand hours of continuous operation. Wire-wrap and jet soldering techniques have been used throughout. Individual package construction utilizes ladder type arrangement of components. The number of components per package greatly reduces the usual number of mechanical connections; and floating connections are used throughout. Circuit parameters have been derated better than 50%. Computer operation is such that complete protection is provided for the prevention of the stored program or constants from being inadvertently destroyed by the operator or an external disturbance.

ADDITIONAL FEATURES AND REMARKS

Outstanding features include high performance and speed, high reliability, protected program storage, flexible instruction vocabulary, use of both core and drum memory, and ease of programming and maintenance. Single instructions can be provided for complex sub-routines without requiring more than one reference to memory.

Unique system advantages include random selection of inputs and outputs in accordance with the program, concurrent input, output and compute operation, and up to 1,000 points per second input selection speed.

The Honeywell Computer Control System utilizing the H290 Computer is applicable for all types of industrial, commercial and military process or operation monitoring and control. Complete application assistance can be provided extending from economical and technical feasibility study through installation and maintenance of the system. All process transmitters, transducers and peripheral equipment can be provided by HONEYWELL.

Concurrent Operation

Execution of internal computations, concurrent with operation of almost any number of peripheral devices (such as paper tape reader, a tape punch, a typewriter, an analog-to-digital converter, etc.) is possible due to the internal logic and random access core memory of the computer. This feature effectively permits the attention of the computer to be devoted to continuous process control of the particular process and to the calculation of process formulae.

For instance, the computer program can randomly select an input channel. If this input channel represents a process variable such as a temperature (read by a thermocouple), its value is usually in analog form (continuous signal) and must be converted to digital form (discrete digits) for presentation to the computer. Conversions of this sort are handled by the computer peripheral equipment; in this case, the analog-to-digital converter. While the computer peripheral equipment carries out this conversion, the computer itself is free to perform other operations. Between operations, the computer "looks at" its input registers to see if the conversion is completed. When the peripheral equipment has completed the requested conversion, the computer is signaled and will accept the digitized value.

The same principle applies to all peripheral operations. All of these can occur concurrently.

Transistorized for Reliability

The Honeywell 290 has solid state components throughout all electronic circuits and is designed to operate in an industrial environment with a minimum of maintenance. Reliability is further assured not only by the low clock rate but also by operating the transistors and diodes far below the maximum levels recommended by the component manufacturers. This lengthens component life. In addition, the Honeywell 290 contains a cooling unit to substantially lower the internal temperature in the computer proper to further increase component life.

HONEYWELL 800

Honeywell 800

MANUFACTURER

Minneapolis Honeywell Regulator Company
Datamatic Division
Newton 61, Massachusetts

APPLICATIONS

Designed for general purpose business, business-scientific, and scientific applications, system capable of running eight programs simultaneously.

PROGRAMMING AND NUMERICAL SYSTEM

Internal number system	Binary and binary-coded decimal
Number of binary digits/word	48
Number of decimal digits/word	12 plus checking
Number of binary digits/instruction	48
Number of decimal digits/instruction	12 plus checking
Number of instructions/word	1
Number of instructions decoded	59 basic types

Photo by Minneapolis Honeywell Regulator Company

Arithmetic system	Floating point (optional) Fixed point (standard)
Instruction type	Three address
Number range	
Decimal $n_d \cdot 10^{e_d}$	$-64 \leq e_d \leq 63$ $-(1 \cdot 10^{-10}) \leq n_d \leq (1 \cdot 10^{-10})$
Binary $n_b \cdot 2^{e_b}$	$-64 \leq e_b \leq 63$ $-(1 \cdot 2^{-39}) \leq n_b \leq (1 \cdot 2^{-39})$

Instruction and information word format

Word Structure - The Honeywell 800 word consists of 54 bits, of which six are used for checking. The 48 information bits may represent an 11-decimal-digit number with its sign, several smaller decimal numbers, with signs for each, eight alphabetic characters, or a combination of these. A word may also be interpreted as a 44-bit binary number with its sign, or as an instruction. Using the floating-point option, a word may represent a sign bit, a seven-bit exponent, and a 40-bit mantissa in binary form.

HONEYWELL 800 WORD STRUCTURE

Type	Example											
Numeric	+ -	1	2	3	4	5	6	7	8	9	0	1
Alphanumeric	R	O	B	I	N	S	O	N				
Alphanumeric Compressed	C	.	W	E	B	B	1	7	4			
Binary	±	(44 Binary Digits)										
Instruction	Operation Code	Address A			Address B			Address C				
Floating Point	±	Exponent (7 Binary Digits)			Mantissa (40 Binary Digits)							

Diagram by Minneapolis-Honeywell Regulator Company

Instructions - In the instruction word, the information bits are divided logically into four sections which are interpreted as an operation code followed by three addresses.

Instruction Word

Operation Code	Address A	Address B	Address C
12 bits	12 bits	12 bits	12 bits

Indexing - Each address in an instruction may be designated as absolute or indexed. A total of eight index registers are available to each program.

Masking - The ability to mask words allows most internal processing instructions in the Honeywell 800 to work with fields of variable length. Each program may designate a group of 32 memory locations as masking registers. Such a designation may be changed by the programmer at any point in his program. Thus, an essentially unlimited number of masking registers is at his disposal.

Automatic built-in subroutines

- Exponential Overflow
- Exponential Underflow
- Division over Capacity
- Addition or Subtraction Overflow
- Read or Write Error
- Begin or End of Tape
- Parity Failure

Automatic coding
 Argus (Automatic Routine Generating and Updating System)
 Fact (Fully Automatic Compiling Technique)
 Algebraic Compiler
 Library of Subroutines
 Executive Routine
 Registers and B-boxes
 64 Index Registers
 8 Mask Index Registers
 32 Input-Output Control
 32 Sequencing and History
 96 Special (Programmer's Usage)
 8 Automatic Subroutines
 16 Internal Control
 Accumulator Register
 Low Order Product-Quotient Register
 Mask Constant Storage Register
 Program Control Register
 Machine Control Register

ARITHMETIC UNIT

	Incl. Stor. Access
	Microsec.
Add time	24
Mult time	162
Div time	450
Construction, arithmetic unit only	
Vacuum tubes	None
Transistors	2,000
Condenser-Diodes	10,000 diodes
Arithmetic mode	Parallel-Serial-Parallel
Timing	Synchronous
Operation	Concurrent

STORAGE

Medium	No. of Words	No. of Digits	Access
			Microsec
Ferrite Cores	Up to 32,000	Up to 384,000	2.1
Magnetic Tape			
No. of units that can be connected		64 Units	
No. of chars per linear inch		533 Chars/inch	
No. of decimal digits per linear in.		800 dd/inch	
Channels or tracks on the tape		10 Tracks/tape	
Blank tape separating each record		0.66 Inches	
Tape speed		120 Inches/sec	
Transfer rate		64,000 Chars/sec	
Decimal digit transfer rate		96,000 dd/sec	
Start time		3.5 Millisec	
Stop time		3.5 Millisec	
Average time for experienced operator to change reel		30 Seconds	
Physical properties of tape			
Width		3/4 Inches	
Length of reel		2,400 Feet + leaders	
Composition		1.5 mil mylar	

INPUT

Media	Speed
Punched Cards	240 cards/min
	650 cards/min
Paper Tape	200 chars/sec
	1,000 chars/sec

OUTPUT

Media	Speed
Punched Cards	100 cards/min
	250 cards/min
Printer	150 lines/min
	900 lines/min
Paper Tape	60 chars/sec

CIRCUIT ELEMENTS OF ENTIRE SYSTEM

Type	Quantity
Diodes	30,000
Transistors	6,000

Above excludes peripheral equipment

CHECKING FEATURES

Verification of all data transmission, arithmetic processes, address modification, memory selections, and central processing. Orthotronic correction of tape data and marginal checking for preventive maintenance.

POWER, SPACE, WEIGHT, AND SITE PREPARATION

Power, computer	32 Kw	57 KVA	0.80 pf
Capacity, air conditioner	9.11 Tons		
Weight, computer	15,720 lbs		

Requirements for the physical installation of a typical system are approximately as follows:

Data Processing Area	1,200 square feet
Service Engineering Area	400 square feet
(including parts storage)	
Ceiling Height	8 feet
Floor Load Capacity	75 lbs/square feet (max)

It is recommended that a raised floor be installed over the existing base floor for the protection of interconnecting cables. This floor should be a free-access type, 9 inches high with a minimum of 5 1/2 inches clearance underneath for accommodating cables.

PRODUCTION RECORD

Deliveries start in December 1960.

COST, PRICE AND RENTAL RATES

Figures given are for a typical system.

Basic system, including a Central Processor, 4,096 words of memory, High-Speed Printer Type Control, High-Speed Card Reader, Six Magnetic Tape Units, High Speed Card Punch, Printer-Card, Reader-Card Punch Control.

Purchase price	\$975,000
Floating-point option	101,800
Additional memory blocks	153,600
(4,096 words/block)	
Rental, basic system above, monthly	20,665
Rental, floating point option, monthly	2,100
Rental, additional memory blocks	3,200

Maintenance service contract available.

PERSONNEL REQUIREMENTS

Personnel requirements depend on equipment configuration and application. Complete training courses for programming and operating staff included with purchase and rental charge.

RELIABILITY, OPERATING EXPERIENCE, AND TIME AVAILABILITY

Each unit and entire system incorporate fail-safe checking. Special construction techniques minimize cold-solder joints and intermittent contacts. All units are designed for simplicity of maintenance and speed of replacement of parts.

ADDITIONAL FEATURES AND REMARKS

Outstanding features include parallel processing, traffic control, system modularity, outstanding system reliability, open-ended design, automatic programming aids (FACT, ARGUS, Algebraic compiler).

Unique system advantages include ability to run up to 8 programs simultaneously without any special programming or special instructions.

Special procedures for magnetic tape labelling, storing, shipping, and protection from humidity, temperature, electrical, fire, or other damage are that relative humidity in area should be held at approximately 40% to insure maximum tape life, dry bulb temperature shall not exceed 74°F, and wet bulb temperature shall not exceed 59°F.

INSTALLATIONS

Army Map Service
6500 Brooks Lane
Washington 25, D. C.

Ames Research Center
Moffett Field, California (Anticipated)

AVCO Corporation
Crosley Division
1329 Arlington Street
Cincinnati 29, Ohio (Proposed)

HRB SINGER

Haller Raymond and Brown - Singer Electronic
Memory Computer

MANUFACTURER

Singer Manufacturing Company
HRB-Singer, Incorporated, Subsidiary
Science Park, State College, Pennsylvania

APPLICATIONS

It will accept numerical information for storage from either a push button or telephone input. It will readout on tape, punch tape or cards or vocally. Confirmation of instructions is obtained so corrections can be made prior to telling the machine to proceed.

STORAGE

	No. of	Access
	Words	Microsec
Medium		
Magnetic Drum	1,024	5,000
16 binary digits per word		

INPUT

Media	Speed
Telephone	regular dial telephone
Ten-key Push Button	
Telephone can be located any place. Vocal confirmation is given.	

OUTPUT

Medium	Speed
Paper Tape	1 line/second
Regular adding machine output	

Photo by HRB - Singer

POWER, SPACE, WEIGHT, AND SITE PREPARATION

Power, computer	0.01 Kw
Volume, computer	5 cu ft
Area, computer	2.25 sq ft
Weight, computer	85 lbs

Nothing is required in the way of site preparation.

PRODUCTION RECORD

Number produced to date	Several
Number in current production	Several

COST, PRICE AND RENTAL RATES

Price of basic system, including telephone and push button input, printed paper tape output and computer	\$15,000
Additional 1,024 word storage drum	4,000
Monthly rental rate for basic system	400

RELIABILITY, OPERATING EXPERIENCE, AND TIME AVAILABILITY

Attempted to run time 167 Hours/Week (Average)
Time is available for rent to outside organizations.

ADDITIONAL FEATURES AND REMARKS

Outstanding features include low cost solution to critical inventory problems.

INSTALLATIONS

HRB - Singer, Inc.
State College, Pa.